

BỘ GIÁO DỤC VÀ ĐÀO TẠO

TOÁN

TOÁN 1



NHÀ XUẤT BẢN GIÁO DỤC VIỆT NAM

BỘ GIÁO DỤC VÀ ĐÀO TẠO

ĐỖ ĐÌNH HOAN (Chủ biên)
NGUYỄN ÁNG – ĐỖ TRUNG HIỆU – PHẠM THANH TÂM

TOÁN 1

(Tái bản lần thứ m ời hai)

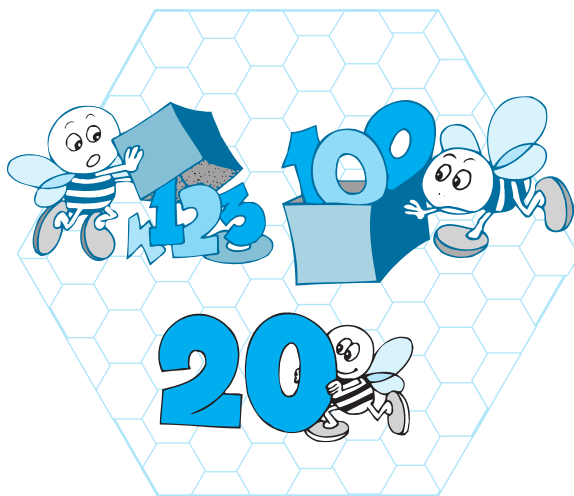

NHÀ XUẤT BẢN GIÁO DỤC VIỆT NAM

Bản quyền thuộc Nhà xuất bản Giáo dục Việt Nam - Bộ Giáo dục và Đào tạo

01-2014/CXB/67-1062/GD

Mã số : 1H103T4

1. CÁC SỐ ĐẾN 10. HÌNH VUÔNG, HÌNH TRÒN, HÌNH TAM GIÁC

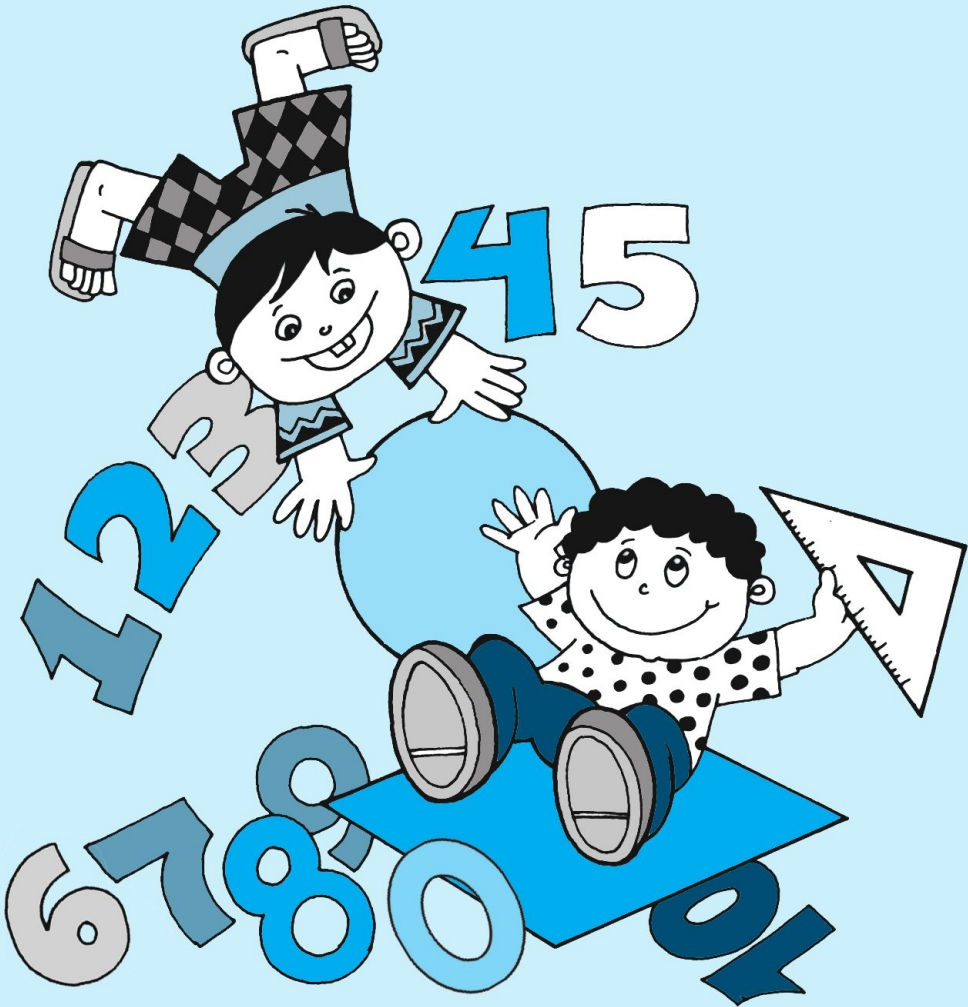

TIẾT HỌC ĐẦU TIÊN



Cô giáo giới thiệu sách Toán 1



Học số



Tập đo độ dài

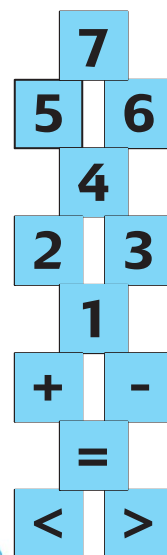



Cả lớp trong giờ học toán

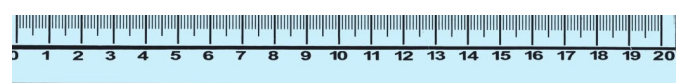
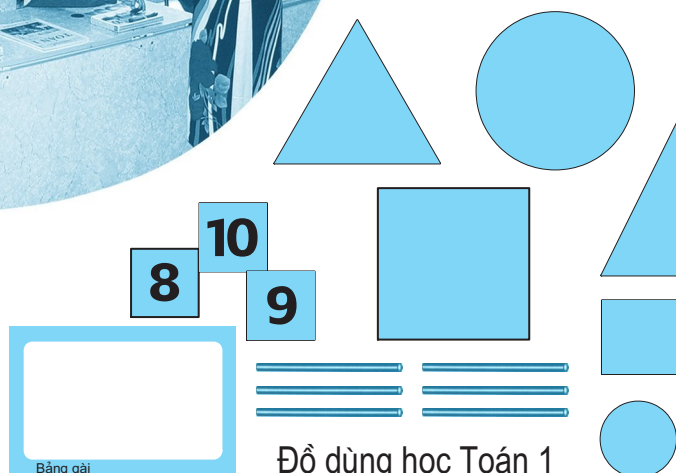
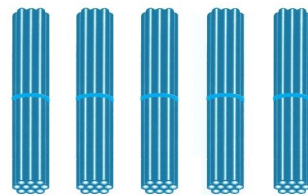

Học nhóm





NHIỀU HƠN, ÍT HƠN

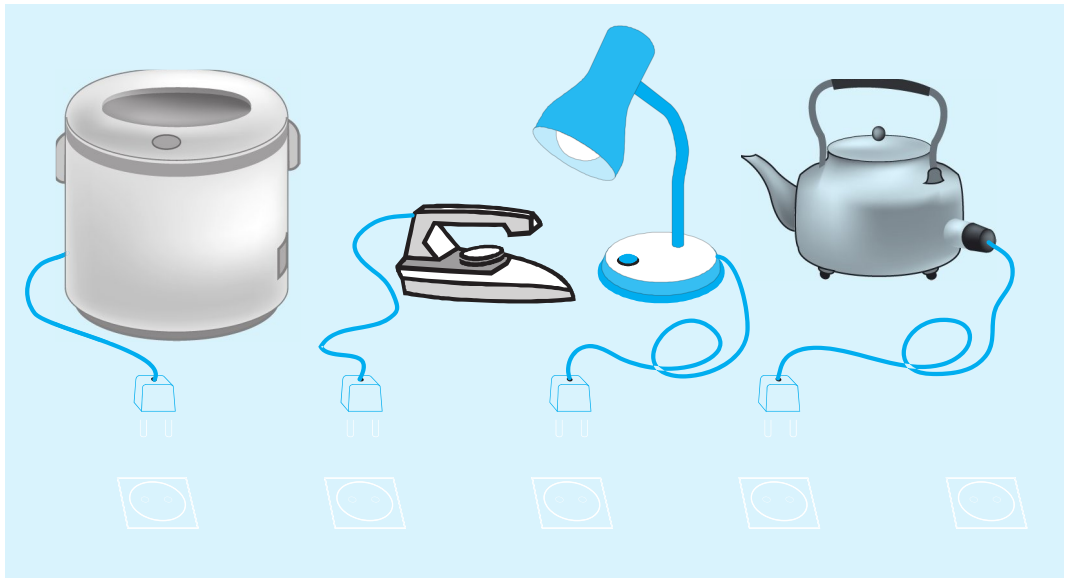
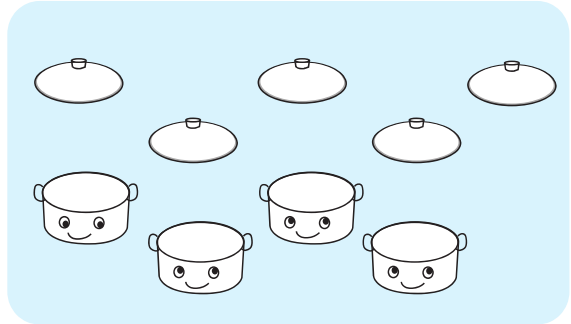
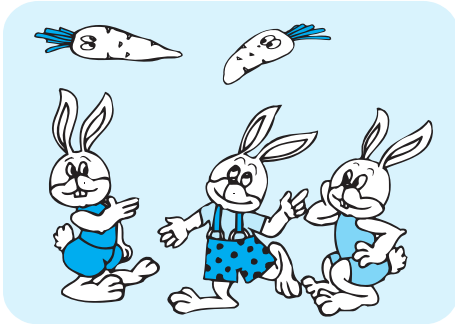
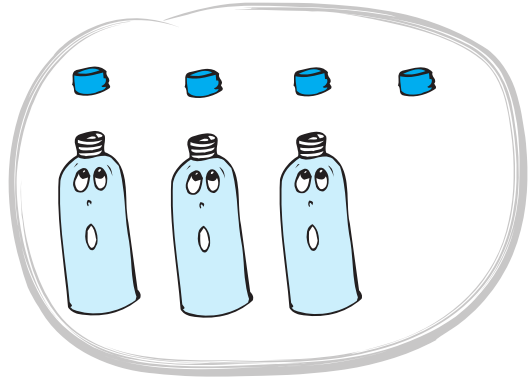
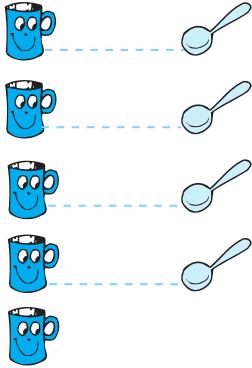

HÌNH VUÔNG, HÌNH TRÒN

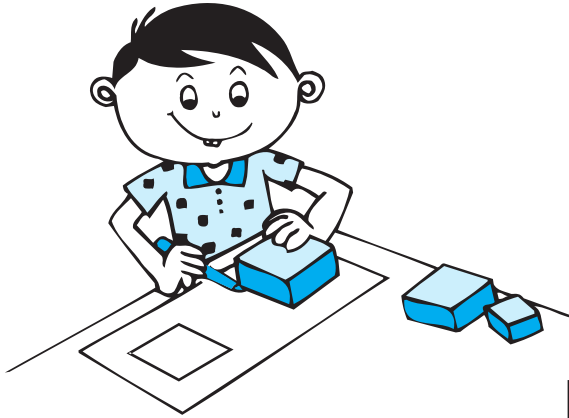
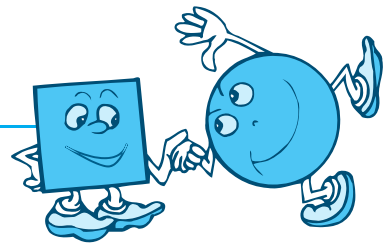

Hình vuông

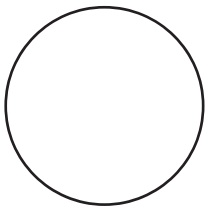
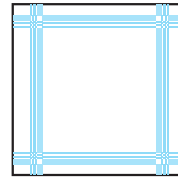

Hình tròn

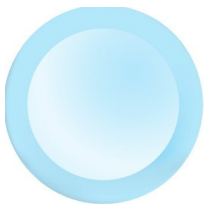
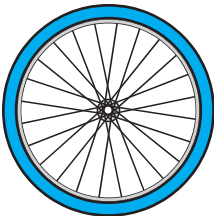

1  Tô màu :

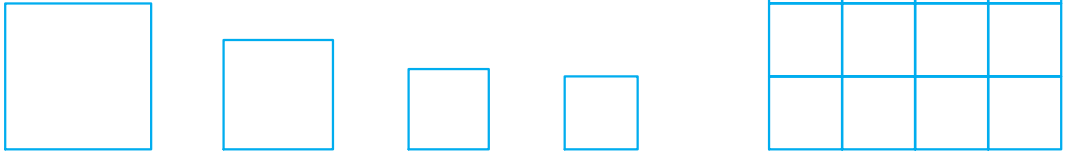

2  Tô màu :

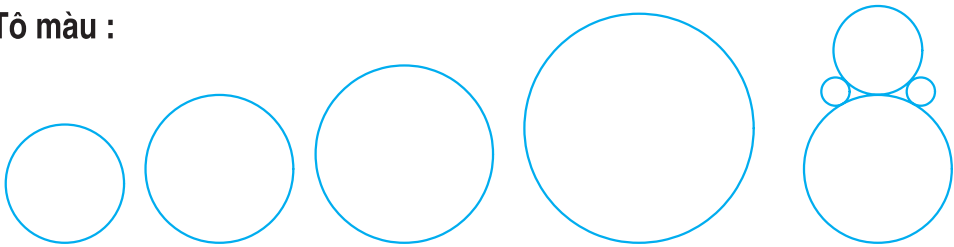

3  Tô màu :

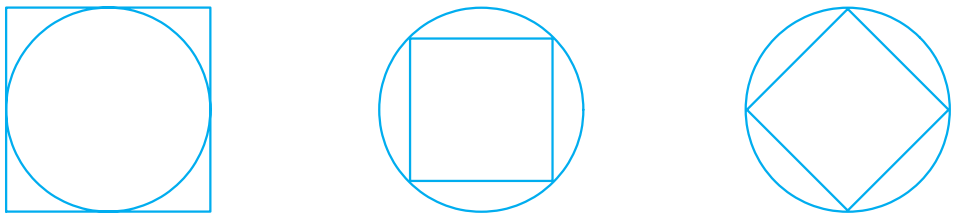

4  Làm thế nào để có các hình vuông ?

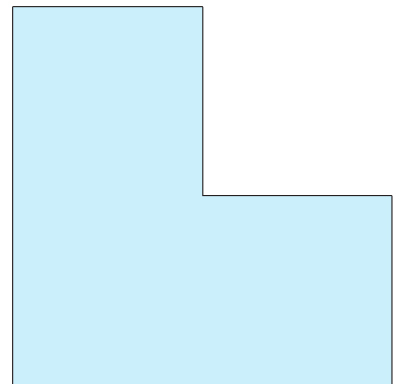
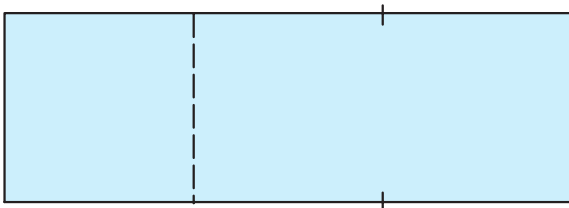

HÌNH TAM GIÁC

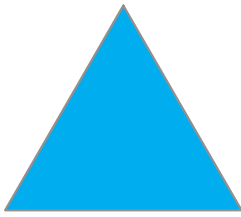

Hình tam giác

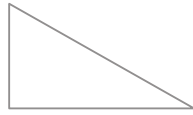

Hình tam giác

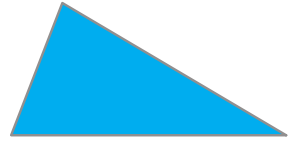

Hình tam giác

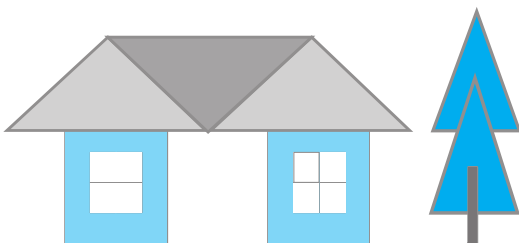
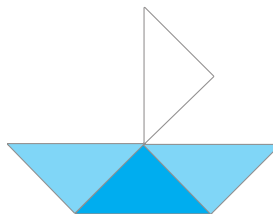
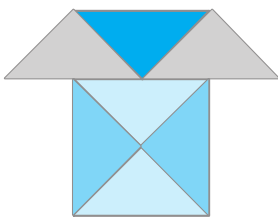
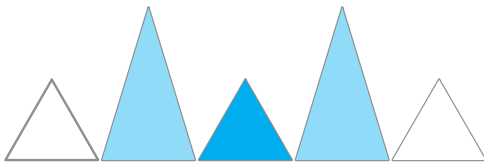
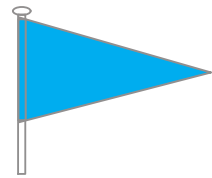
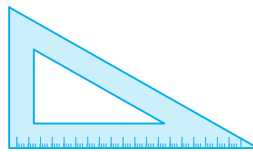



LUYỆN TẬP

1  Tô màu vào các hình : cùng hình dạng thì cùng một màu.

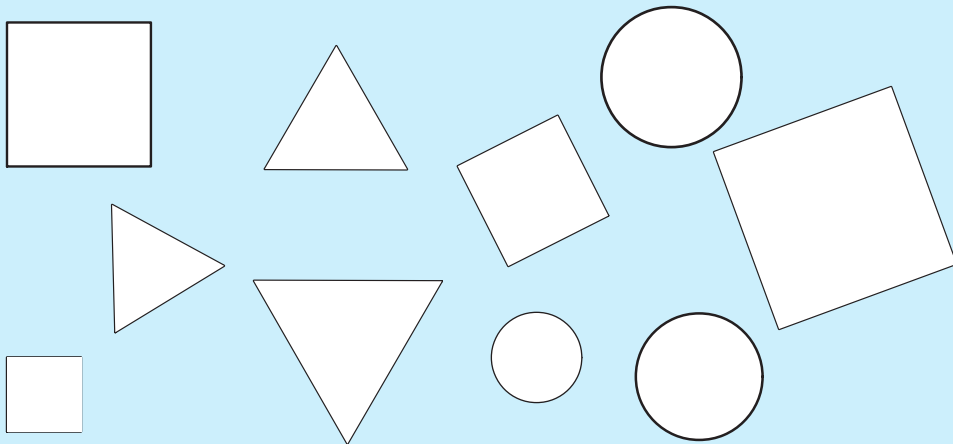

2  Ghép lại thành các hình mới :

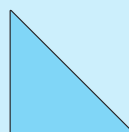
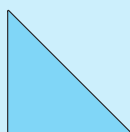
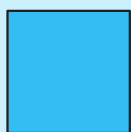

Ví dụ :

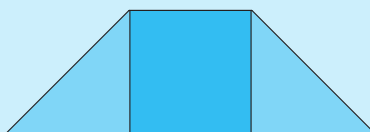

a)

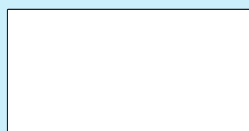

b)

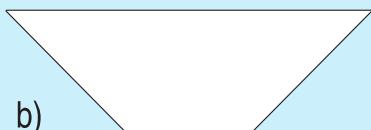

c)



CÁC SỐ 1, 2, 3

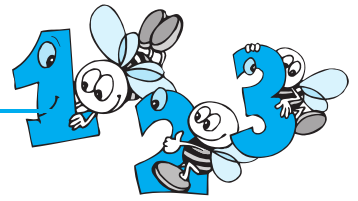

1

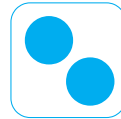
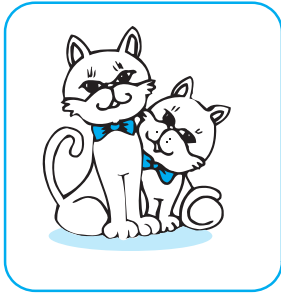

2

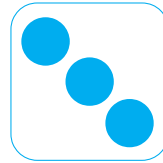
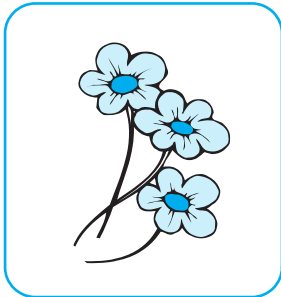

3

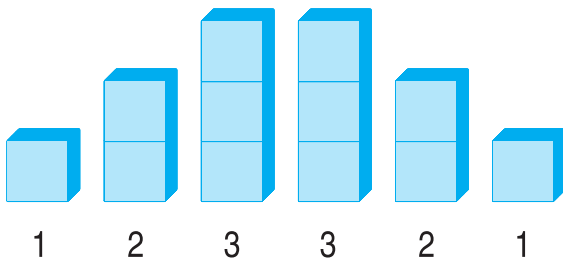

1	2
---	---

2	1
---	---

1	2	3
---	---	---

3	2	1
---	---	---

1  **Viết số 1, 2, 3 :**

1																			
---	--	--	--	--	--	--	--	--	--	--	--	--	--	--	--	--	--	--	--

2																			
---	--	--	--	--	--	--	--	--	--	--	--	--	--	--	--	--	--	--	--

3																			
---	--	--	--	--	--	--	--	--	--	--	--	--	--	--	--	--	--	--	--

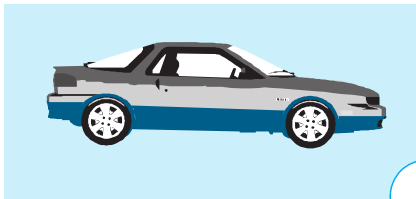

2  **Viết số vào ô trống (theo mẫu) :**



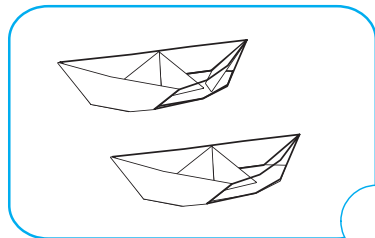
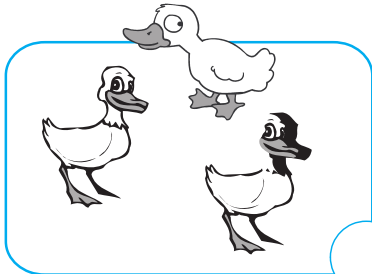
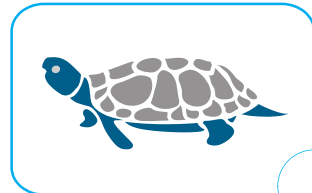
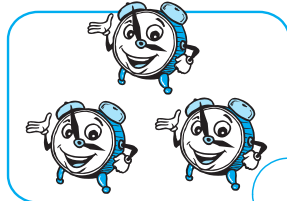
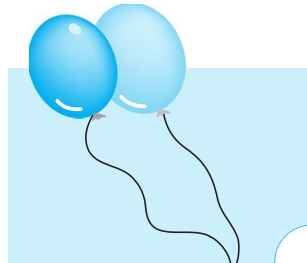

1



3  **Viết số hoặc vẽ số chấm tròn thích hợp :**

3	2	1

		
	3	

LUYỆN TẬP



1  Số ?

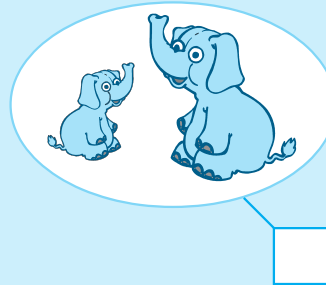
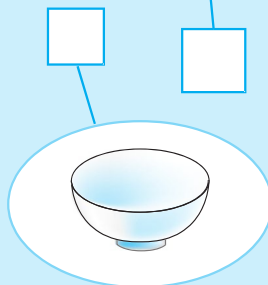
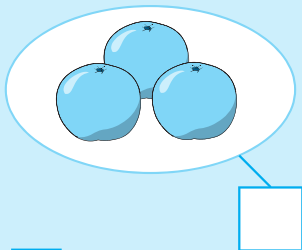
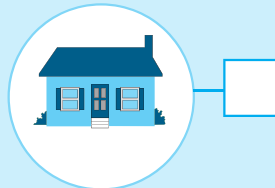
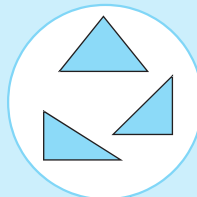
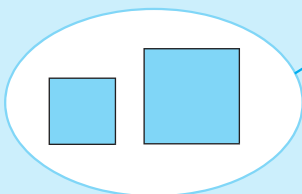

2  Số ?



1	2	3
---	---	---

<input type="text"/>	2	1
----------------------	---	---

3	<input type="text"/>	1
---	----------------------	---

3	2	<input type="text"/>
---	---	----------------------

1	2	<input type="text"/>
---	---	----------------------

1	<input type="text"/>	<input type="text"/>
---	----------------------	----------------------

3  Số ?

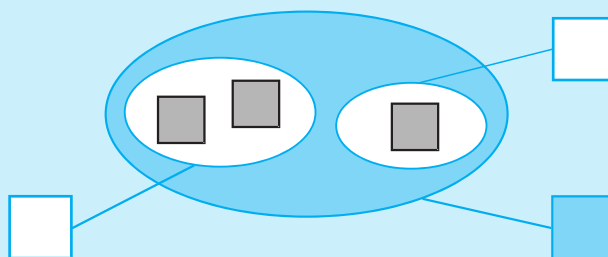

4  Viết số 1, 2, 3 :

1	2	3																	
---	---	---	--	--	--	--	--	--	--	--	--	--	--	--	--	--	--	--	--



CÁC SỐ 1, 2, 3, 4, 5

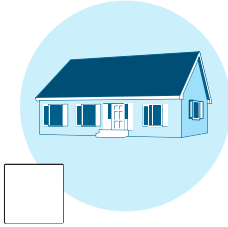

□

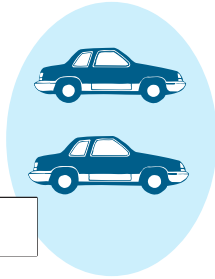

□

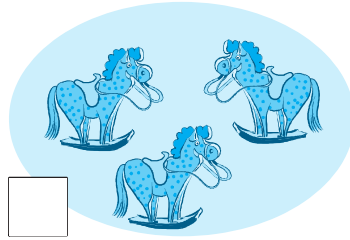

□

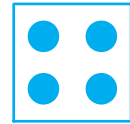
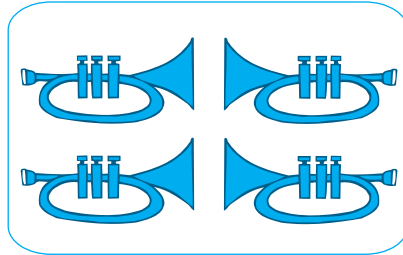
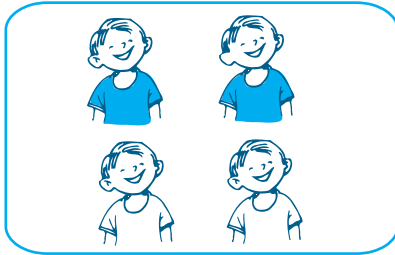

4 4

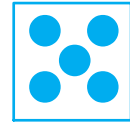
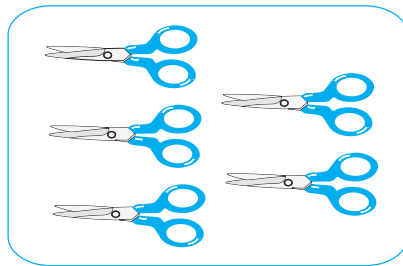
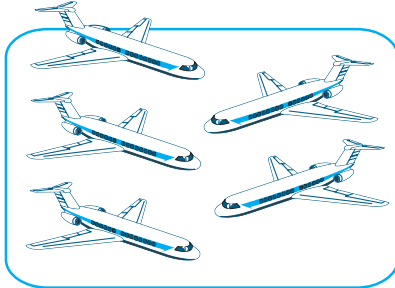

5 5

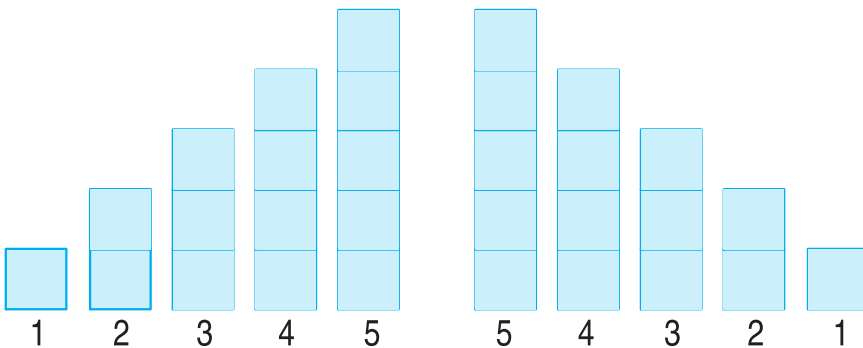

1	2	3	4	5
---	---	---	---	---

5	4	3	2	1
---	---	---	---	---

1		3		5
---	--	---	--	---

5			2	
---	--	--	---	--

1  **Viết số 4, 5 :**

4																			
5																			

2  **Số ?**

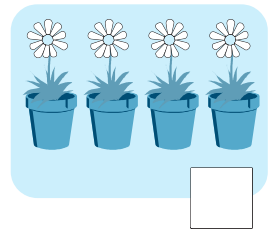
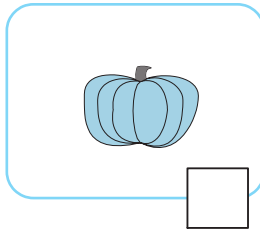
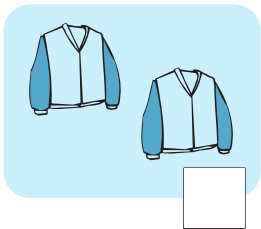
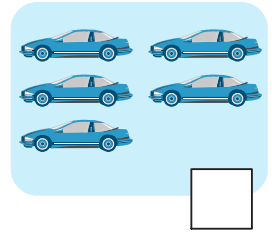
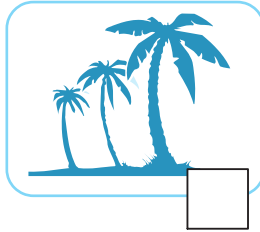
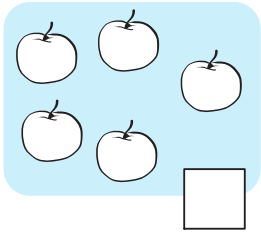



3  **Số ?**

1	2	□	4	□
5	4	●	2	■

1	2	□	4	□
5	■	3	2	■

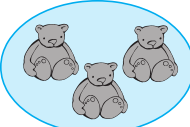

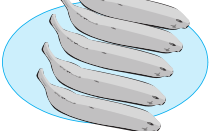
4  **Nối (theo mẫu) :**

				
●	●●●	●●●●	●●	●●●●●
1	2	3	4	5



LUYỆN TẬP

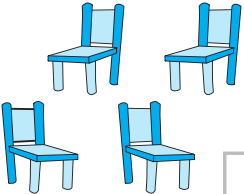

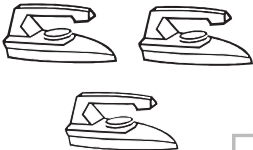
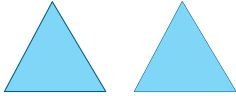
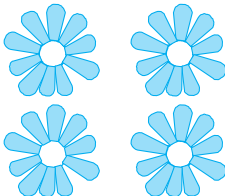

1  Số ?

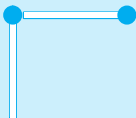
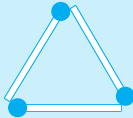
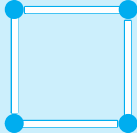
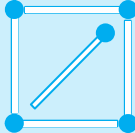
		
<input type="text"/>	<input type="text"/>	<input type="text"/>
		
<input type="text"/>	<input type="text"/>	<input type="text"/>

2  Số ?

				
<input type="text"/>	<input type="text"/>	<input type="text"/>	<input type="text"/>	<input type="text"/>

3  Số ?

1	2			5	1		3		
1	2		4		5	4	3		
		3	5			4	2		

4  Viết số 1, 2, 3, 4, 5 :

1	2	3	4	5															
---	---	---	---	---	--	--	--	--	--	--	--	--	--	--	--	--	--	--	--

BÉ HƠN. DẤU <

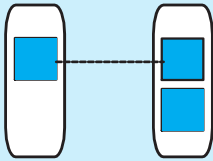
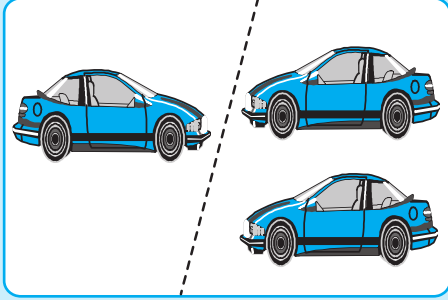

$1 < 2$
một bé hơn hai

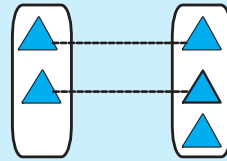
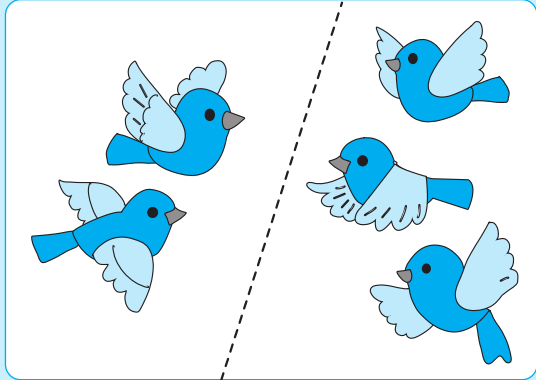

$2 < 3$
hai bé hơn ba

1 Viết dấu <



2 Viết (theo mẫu) :

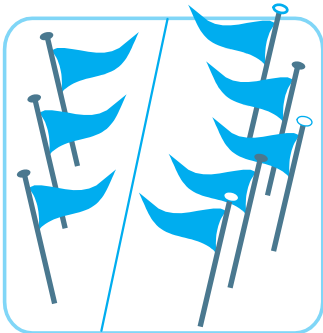

3 < 5

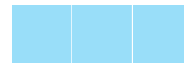
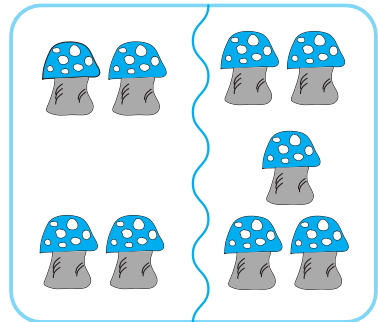
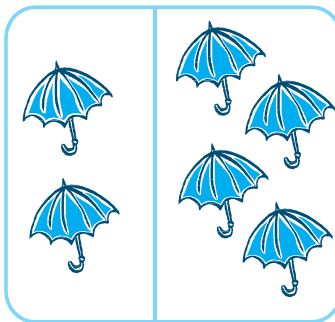

3  **Viết (theo mẫu) :**

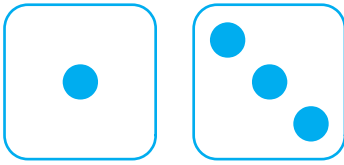

$$1 < 3$$

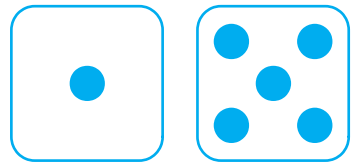
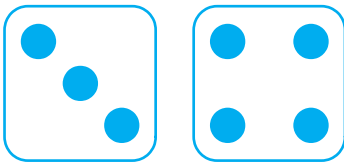
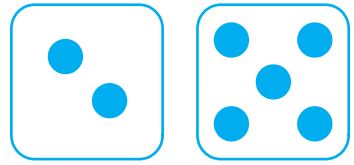

4  **Viết dấu < vào ô trống :**

$1 \square 2$

$2 \square 3$

$3 \square 4$

$4 \square 5$

$2 \square 4$

$3 \square 5$

5  **Nối \square với số thích hợp (theo mẫu) :**

$1 < \square$

$3 < \square$

1

2

3

4

5

$2 < \square$

$4 < \square$

LỚN HƠN. DẤU >



$2 > 1$
hai lớn hơn một

$3 > 2$
ba lớn hơn hai









1 Viết dấu >

>																			
---	--	--	--	--	--	--	--	--	--	--	--	--	--	--	--	--	--	--	--

2 Viết (theo mẫu) :

$5 > 3$

3  **Viết (theo mẫu) :**

															
															
<table border="1" style="width: 100%;"><tr><td>4</td><td>></td><td>3</td></tr></table>	4	>	3	<table border="1" style="width: 100%;"><tr><td> </td><td> </td><td> </td></tr></table>				<table border="1" style="width: 100%;"><tr><td> </td><td> </td><td> </td></tr></table>				<table border="1" style="width: 100%;"><tr><td> </td><td> </td><td> </td></tr></table>			
4	>	3													

4  **Viết dấu > vào ô trống :**

3 <input style="width: 30px; height: 20px;" type="text"/> 1	5 <input style="width: 30px; height: 20px;" type="text"/> 3	4 <input style="width: 30px; height: 20px;" type="text"/> 1	2 <input style="width: 30px; height: 20px;" type="text"/> 1
4 <input style="width: 30px; height: 20px;" type="text"/> 2	3 <input style="width: 30px; height: 20px;" type="text"/> 2	4 <input style="width: 30px; height: 20px;" type="text"/> 3	5 <input style="width: 30px; height: 20px;" type="text"/> 2

5  **Nối với số thích hợp (theo mẫu) :**

<table border="1" style="width: 100%;"><tr><td>2</td><td>></td><td><input style="width: 20px; height: 20px;" type="text"/></td></tr></table>	2	>	<input style="width: 20px; height: 20px;" type="text"/>	<table border="1" style="width: 100%;"><tr><td>5</td><td>></td><td><input style="width: 20px; height: 20px;" type="text"/></td></tr></table>	5	>	<input style="width: 20px; height: 20px;" type="text"/>
2	>	<input style="width: 20px; height: 20px;" type="text"/>					
5	>	<input style="width: 20px; height: 20px;" type="text"/>					
1	2	3	4	5			
<table border="1" style="width: 100%;"><tr><td>3</td><td>></td><td><input style="width: 20px; height: 20px;" type="text"/></td></tr></table>	3	>	<input style="width: 20px; height: 20px;" type="text"/>	<table border="1" style="width: 100%;"><tr><td>4</td><td>></td><td><input style="width: 20px; height: 20px;" type="text"/></td></tr></table>	4	>	<input style="width: 20px; height: 20px;" type="text"/>
3	>	<input style="width: 20px; height: 20px;" type="text"/>					
4	>	<input style="width: 20px; height: 20px;" type="text"/>					



$5 \square 4$

$1 \square 2$

$1 \square 1$

$3 \square 3$

$2 \square 1$

$3 \square 4$

$2 \square 5$

$2 \square 2$

$3 \square 2$

4  Viết (theo mẫu) :

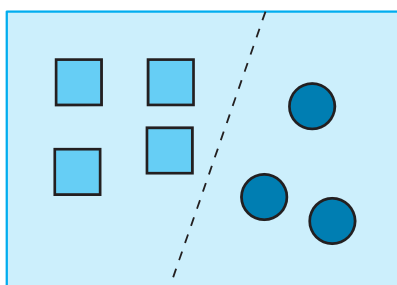

$4 > 3$

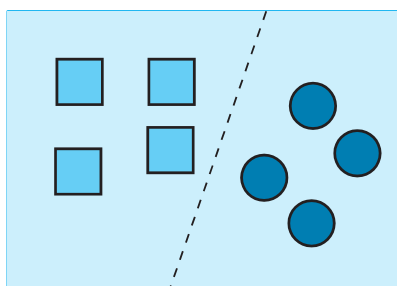
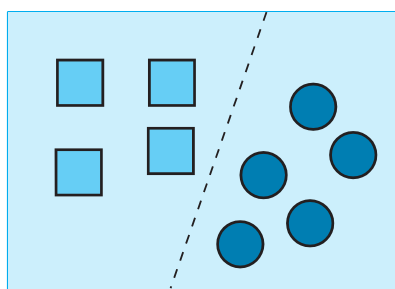



LUYỆN TẬP

1



3...2
1...2
2...2

4...5
4...4
4...3

2...3
3...4
2...4

2

Viết (theo mẫu) :

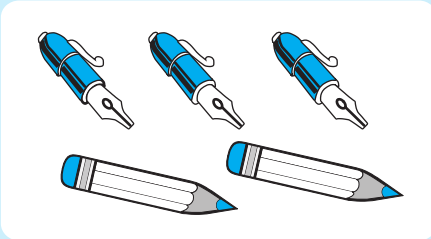

3 > 2

2 < 3

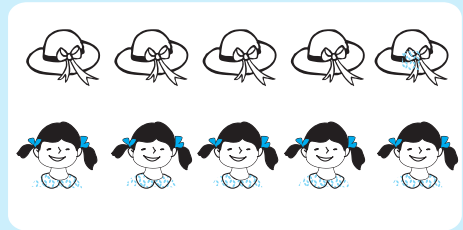
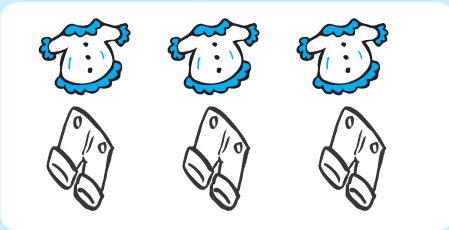
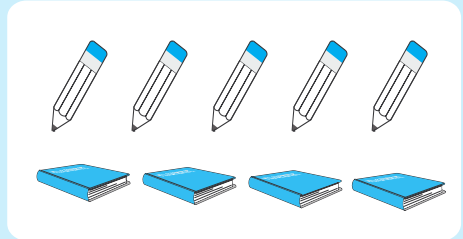

3

Làm cho bằng nhau (theo mẫu) :

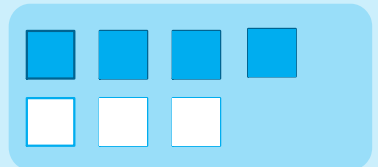
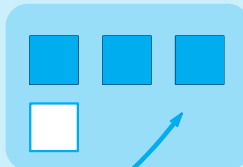
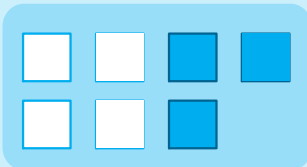

3 = 3

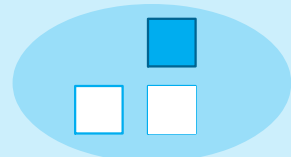
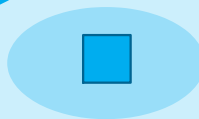
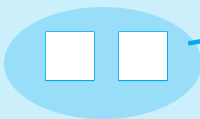

LUYỆN TẬP CHUNG



1  Làm cho bằng nhau :

a) Bằng cách vẽ thêm :

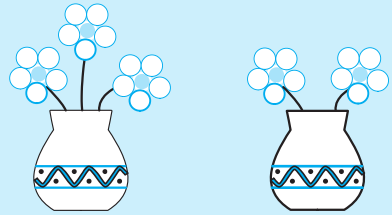

b) Bằng cách gạch bớt :

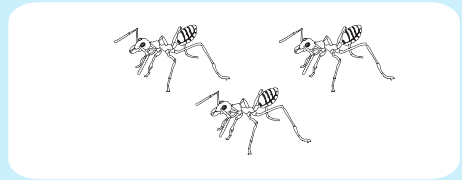
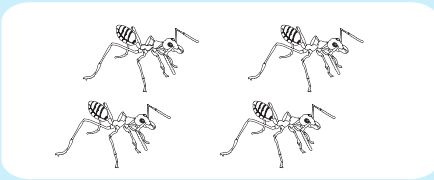

c) Bằng cách vẽ thêm hoặc gạch bớt :

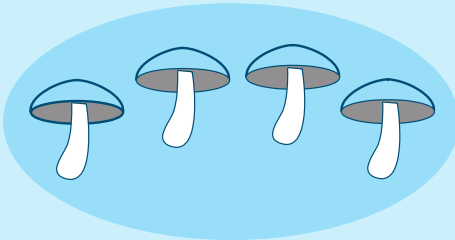

2  Nối với số thích hợp (theo mẫu) :

< 2

< 3

< 5

1

2

3

4

5

3  Nối với số thích hợp :

2 >

3 >

4 >

1

2

3



SỐ 6

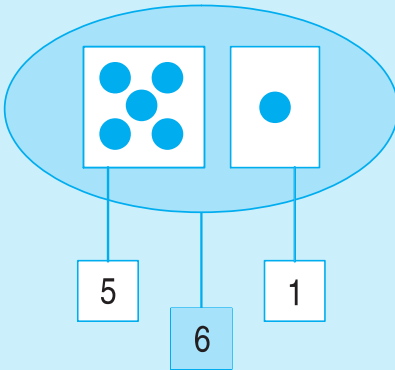
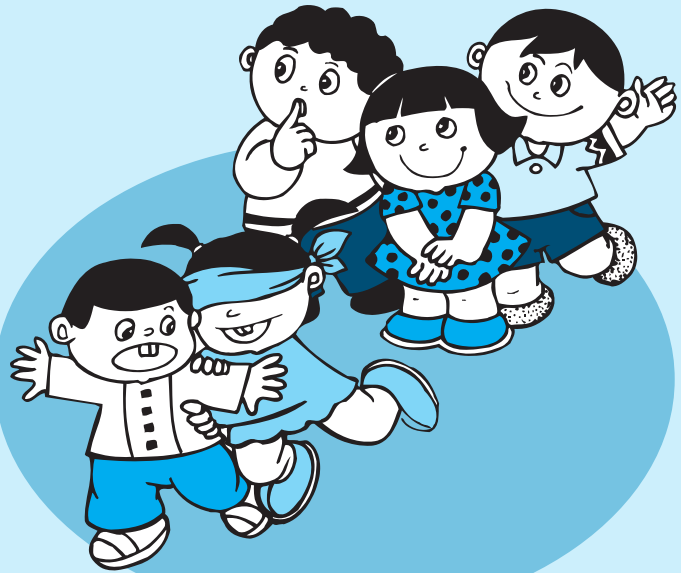

6



1  Viết số 6 :

6																			
---	--	--	--	--	--	--	--	--	--	--	--	--	--	--	--	--	--	--	--

2  **Viết (theo mẫu) :**

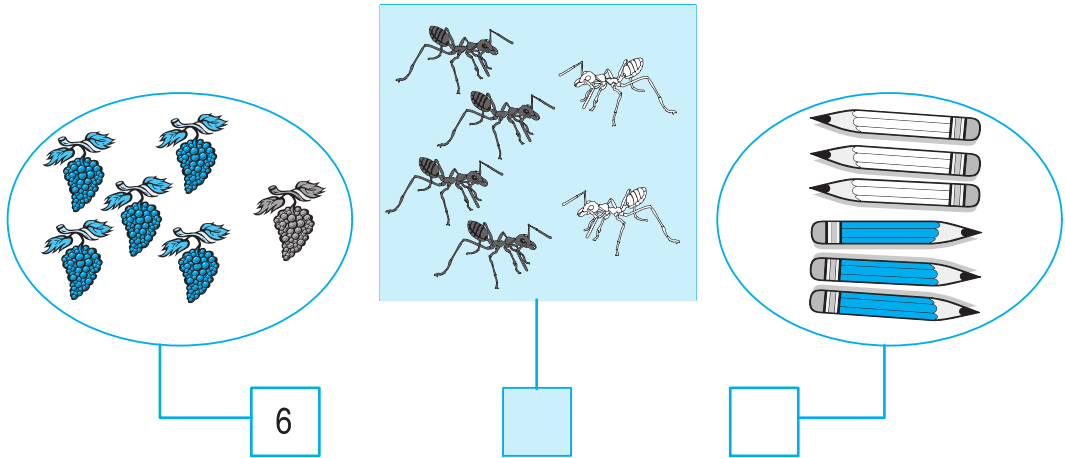

6

3  **Viết số thích hợp vào ô trống :**

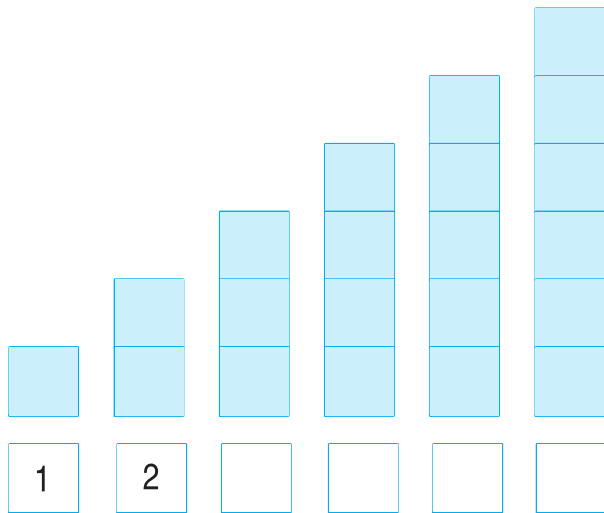















1	2				6
---	---	--	--	--	---

	2		4		
--	---	--	---	--	--

6	5	4	3		
---	---	---	---	--	--

6					1
---	--	--	--	--	---

4  

6		5	6		2	1		2	3		3
6		4	6		1	2		4	3		5
6		3	6		6	4		6	5		6

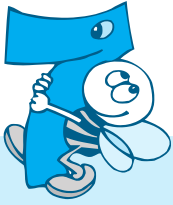

SỐ 7

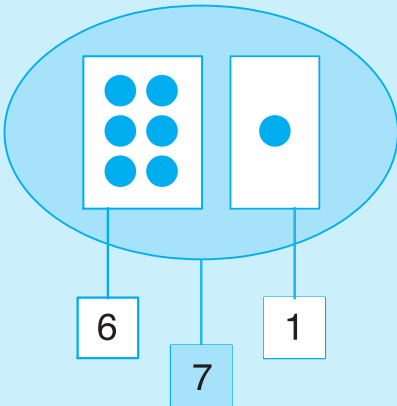
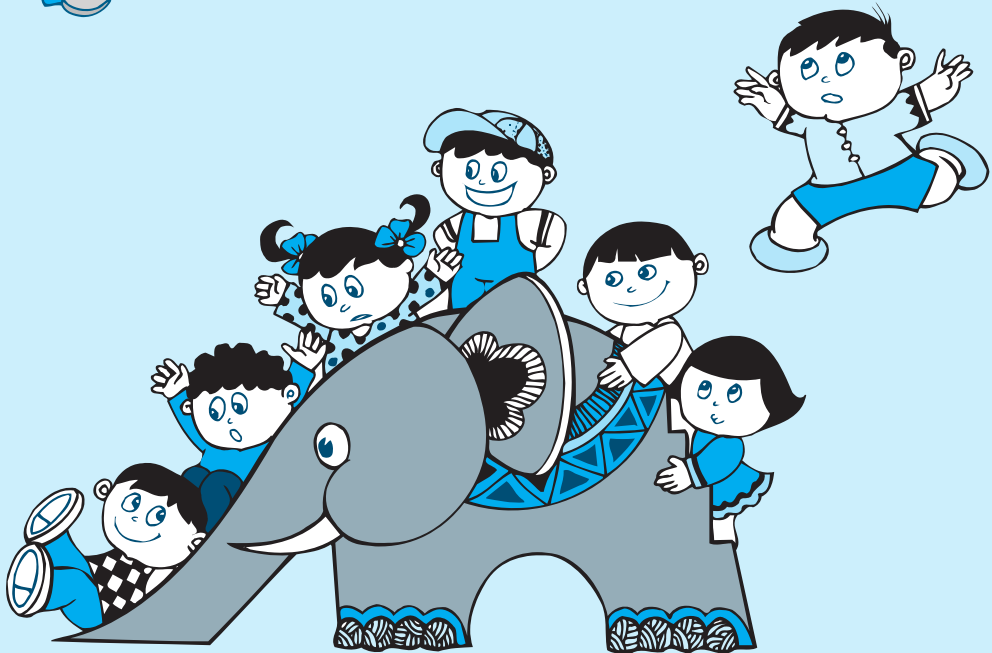

7



1  Viết số 7 :

7																			
---	--	--	--	--	--	--	--	--	--	--	--	--	--	--	--	--	--	--	--

2  Số ?

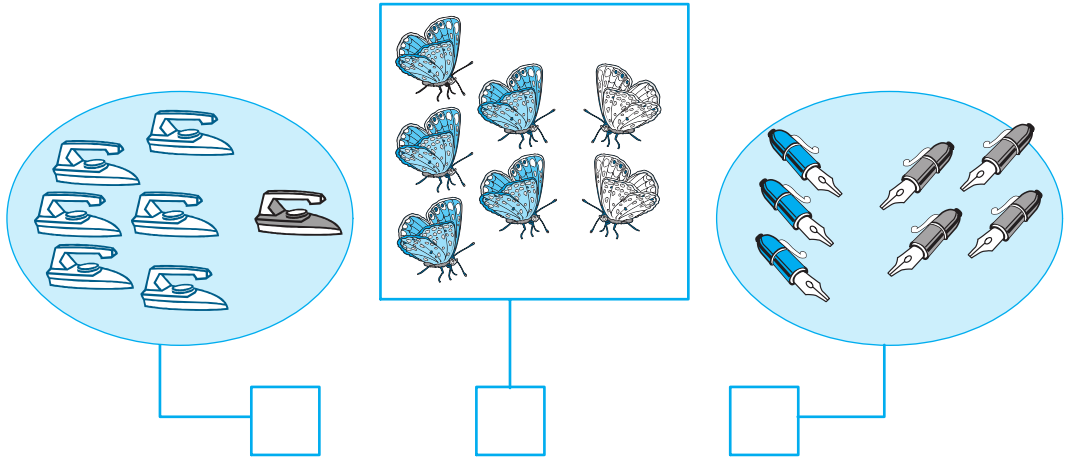





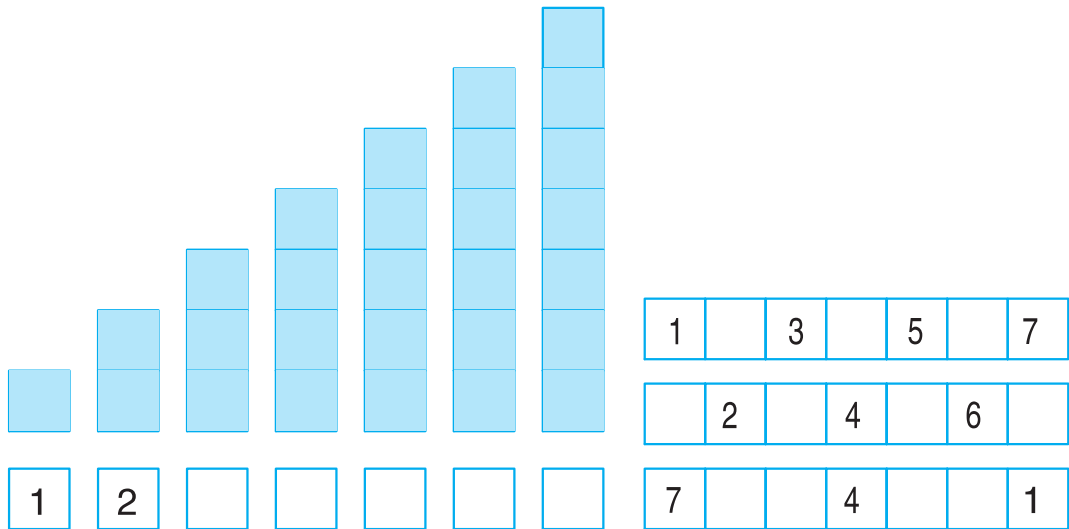





8 irons, 6 butterflies, 7 pens

3  Viết số thích hợp vào ô trống :



1		3		5		7
	2		4		6	
7			4			1

4   ?

7		6	2		5	7		2	6		7
7		3	5		7	7		4	7		7



SỐ 8

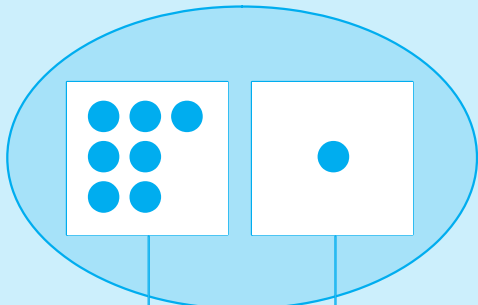
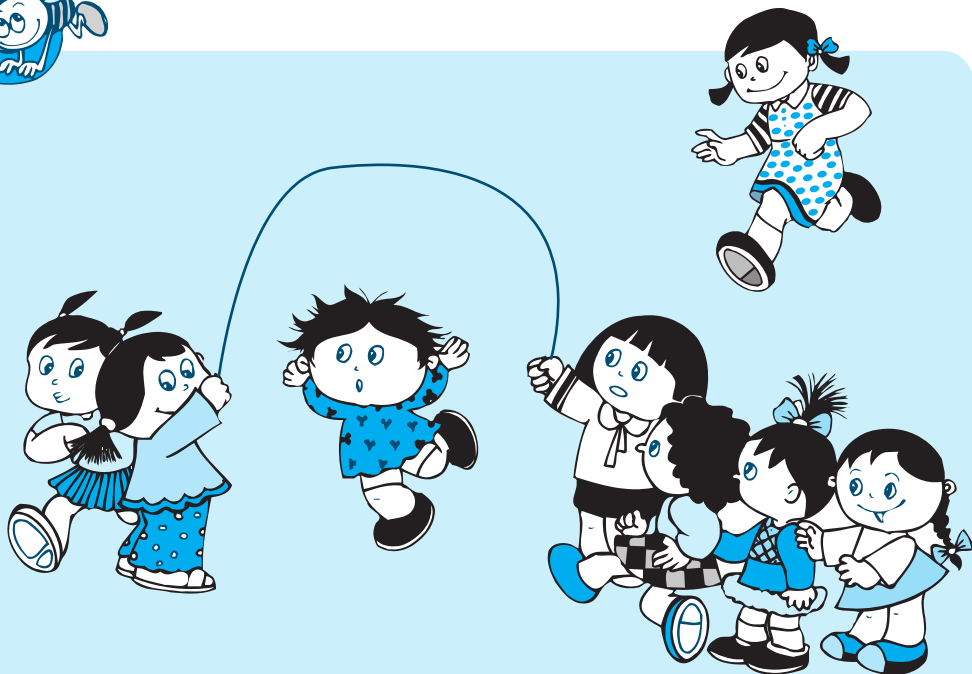

7

1

8



8

1	2	3	4	5	6	7	8
---	---	---	---	---	---	---	---

1  Viết số 8 :

8																			
---	--	--	--	--	--	--	--	--	--	--	--	--	--	--	--	--	--	--	--

2 

Số ?

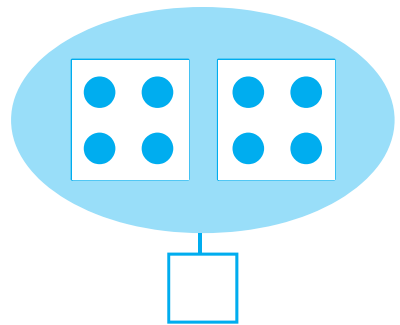
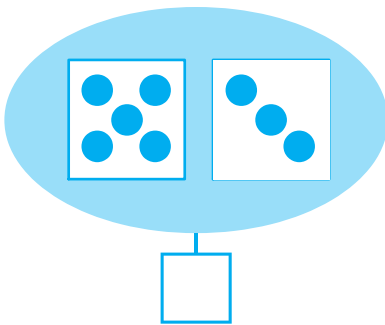
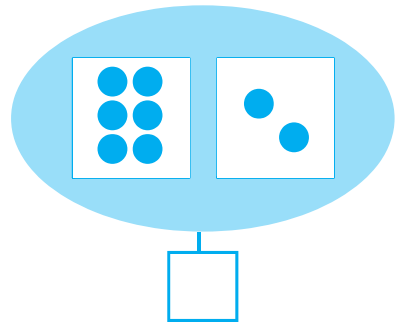
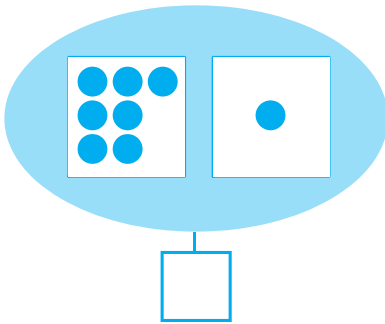

3 

Viết số thích hợp vào ô trống :



4 



8...7

8...6

5...8

8...8

7...8

6...8

8...5

8...4

SỐ 9

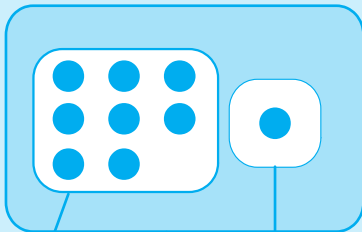

9

8

9

1

1

2

3

4

5

6

7

8



9

1  Viết số 9 :

9																			
---	--	--	--	--	--	--	--	--	--	--	--	--	--	--	--	--	--	--	--

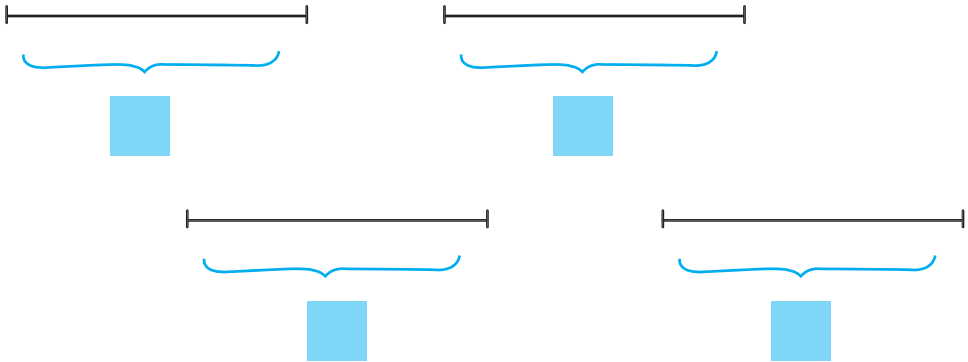
2  Số ?



3   ?

- | | | |
|-------|-------|-------|
| 8...9 | 7...8 | 9...8 |
| 9...8 | 8...9 | 9...7 |
| 9...9 | 7...9 | 9...6 |

4  Số ?

- | | | |
|---------|---------|-------------|
| 8 < ... | 7 < ... | 7 < ... < 9 |
| ... > 8 | ... > 7 | 6 < ... < 8 |

5  Viết số thích hợp vào ô trống :

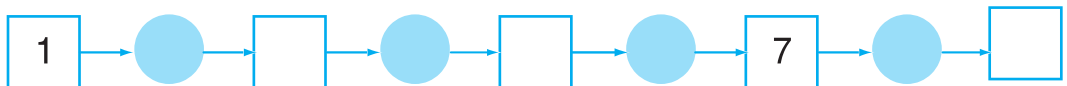

SỐ 0

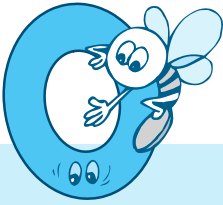

Four fishbowl illustrations showing the process of catching and releasing fish:

- Top-left: A fishbowl with 5 fish. A net is positioned above it. A small empty square box is below.
- Top-right: A fishbowl with 3 fish. A net is tilted, catching 2 fish. A small empty square box is below.
- Bottom-left: A fishbowl with 1 fish. A net is tilted, releasing 1 fish. A small empty square box is below.
- Bottom-right: A fishbowl with 0 fish. A net is tilted, releasing 0 fish. A small empty square box is below.

Counting sequence with dot patterns:

0	1	2	3	4	5	6	7	8	9
---	---	---	---	---	---	---	---	---	---

1  **Viết số 0 :**

0																			
---	--	--	--	--	--	--	--	--	--	--	--	--	--	--	--	--	--	--	--

2  **Viết số thích hợp vào ô trống :**

0	1		3		5
---	---	--	---	--	---



	1				5
--	---	--	--	--	---

			3		
--	--	--	---	--	--

		2				6			9
--	--	---	--	--	--	---	--	--	---

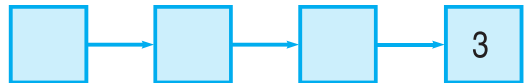
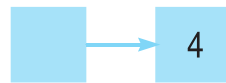
3  **Viết số thích hợp vào ô trống (theo mẫu) :**



4  

0...1

0...5

7...0

8...8

2...0

8...0

0...3

4...4

0...4

9...0

0...2

0...0



SỐ 10

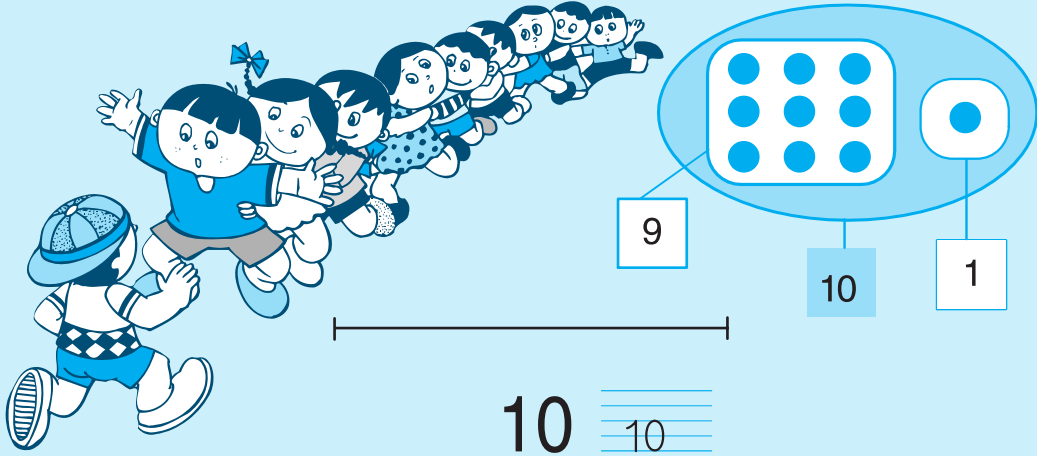

1  Viết số 10 :

10																			
----	--	--	--	--	--	--	--	--	--	--	--	--	--	--	--	--	--	--	--

2  Số ?

Group 1: 6 mushrooms, box:

Group 2: 8 mushrooms, box:

Group 3: 9 mushrooms, box:

Group 4: 10 mushrooms, box:

3  Số ?

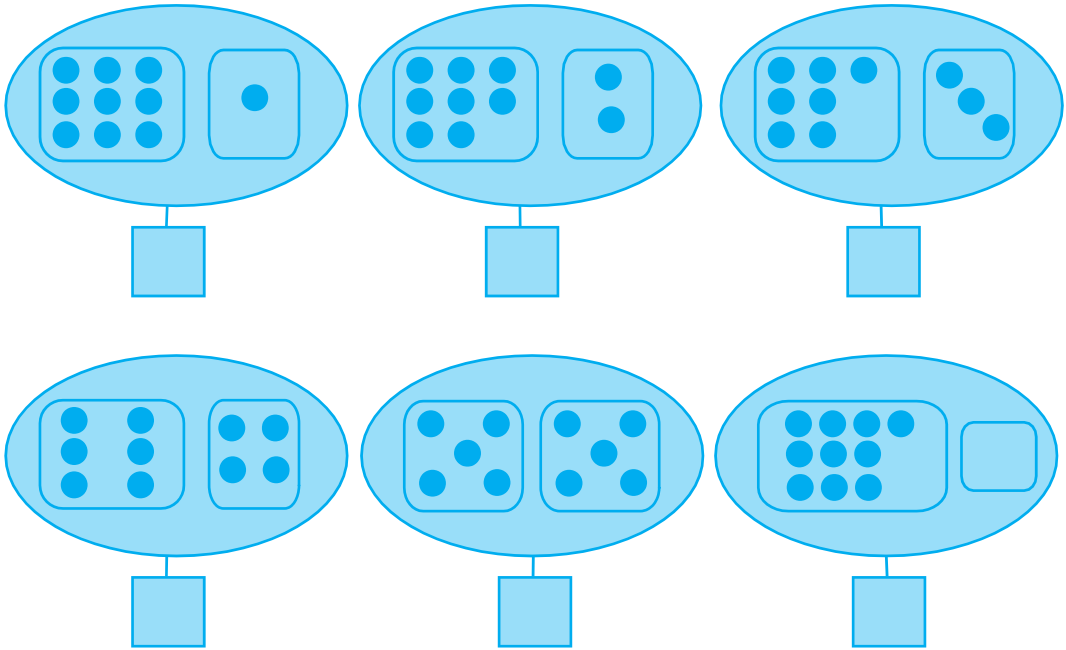

The image shows six ten-frames arranged in two rows of three. Each ten-frame is a large oval containing two smaller rounded rectangles. Below each ten-frame is a small square box for writing the total number of dots.

- Top-left: Left box has 6 dots (2x3), right box has 1 dot. Box below:
- Top-middle: Left box has 6 dots (2x3), right box has 2 dots (1x2). Box below:
- Top-right: Left box has 6 dots (2x3), right box has 3 dots (1x3). Box below:
- Bottom-left: Left box has 5 dots (2x2 + 1), right box has 4 dots (2x2). Box below:
- Bottom-middle: Left box has 5 dots (2x2 + 1), right box has 5 dots (2x2 + 1). Box below:
- Bottom-right: Left box has 8 dots (2x4), right box is empty. Box below:

4  Viết số thích hợp vào ô trống :

0	1			4				8		
10									1	

5  Khoanh vào số lớn nhất (theo mẫu) :

- a) 4 , 2 , 7
- b) 8 , 10 , 9
- c) 6 , 3 , 5 .



LUYỆN TẬP

1  Nói (theo mẫu) :

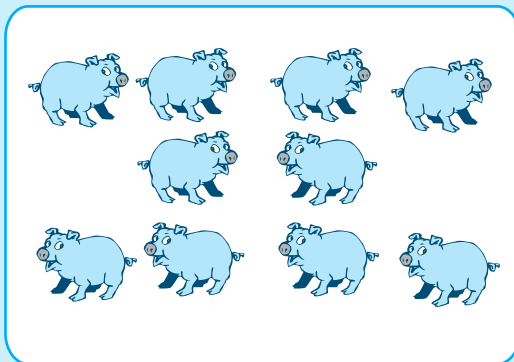
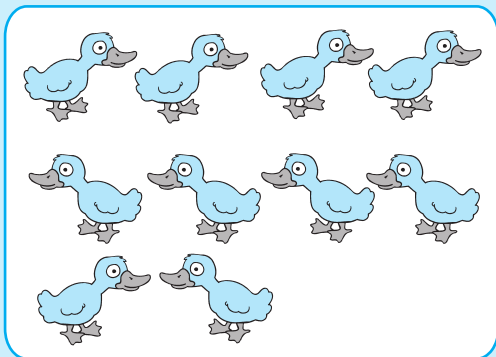

10

9

8

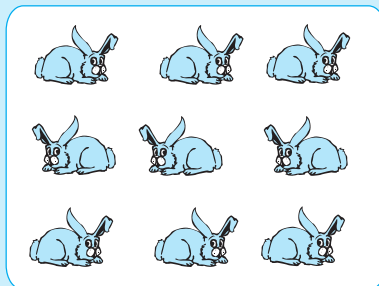
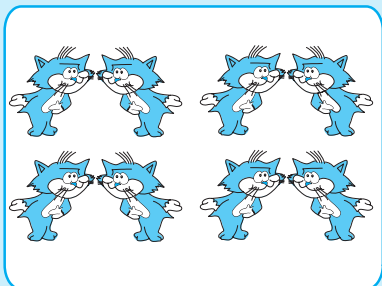

2  Vẽ thêm cho đủ 10 chấm tròn :

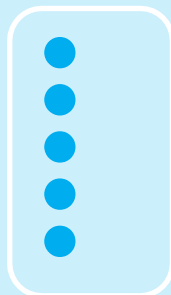
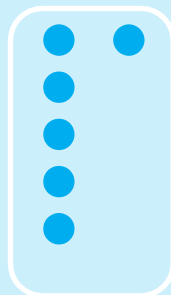
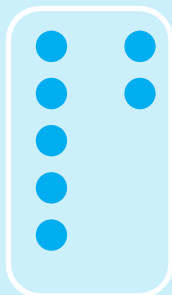
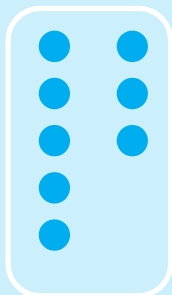
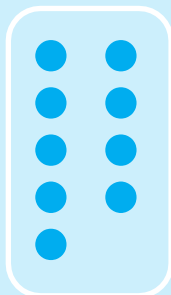

3 Có mấy hình tam giác ?

a)



b)

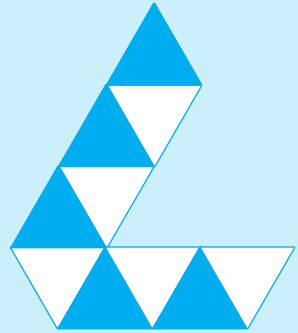

4

a)



0 1

1 2

2 3

3 4

8 7

7 6

6 6

4 5

10 9

9 8

b) Các số bé hơn 10 là :

c) Trong các số từ 0 đến 10 : Số bé nhất là

Số lớn nhất là

5

Số ?

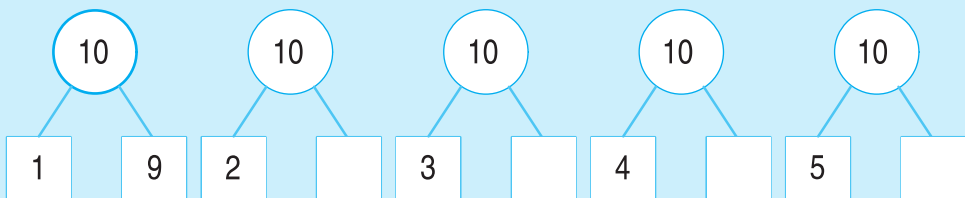



LUYỆN TẬP CHUNG

1  Nói (theo mẫu) :

The diagram features a central flower with ten petals, each containing a number. A blue line connects the center of the flower to an oval containing three chickens. Surrounding the flower are seven other ovals, each containing a different object: five pencils, seven fish, four sailboats, six oranges, and six ice cream cones. There are also two ovals containing flowers: one with five flowers and one with ten flowers.

2  Viết các số từ 0 đến 10 :

3



Số ?

a)

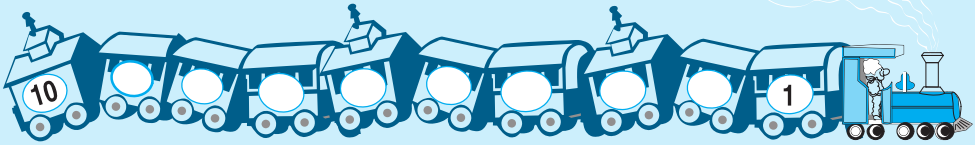

b)

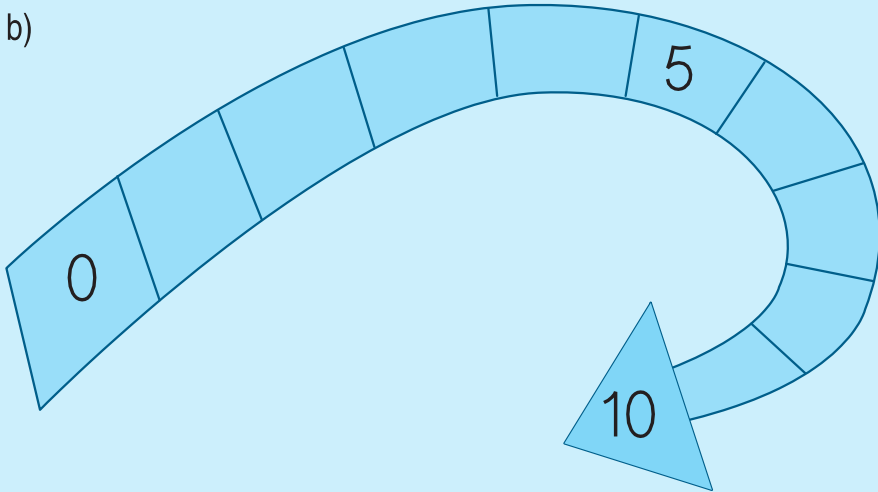

4



Viết các số 6, 1, 3, 7, 10 :

a) Theo thứ tự từ bé đến lớn :

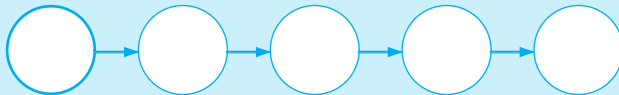

b) Theo thứ tự từ lớn đến bé :



5



Xếp hình theo mẫu sau :





LUYỆN TẬP CHUNG

1 Số ?

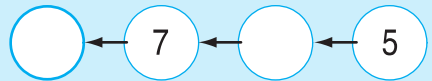
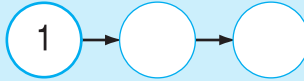
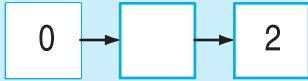

2 ?

4 ... 5

2 ... 5

8 ... 10

7 ... 7

3 ... 2

7 ... 5

4 ... 4

10 ... 9

7 ... 9

1 ... 0

3 Số ?

< 1

> 9

3 < < 5

4 Viết các số 8, 5, 2, 9, 6 :

a) Theo thứ tự từ bé đến lớn :

b) Theo thứ tự từ lớn đến bé :

5 Hình dưới đây có mấy hình tam giác ?

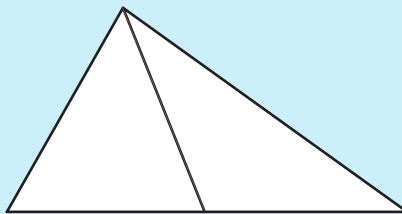

2. PHÉP CỘNG, PHÉP TRỪ TRONG PHẠM VI 10





PHÉP CỘNG TRONG PHẠM VI 3

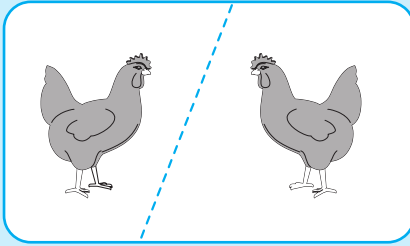

$1 + 1 = 2$
một cộng một bằng hai

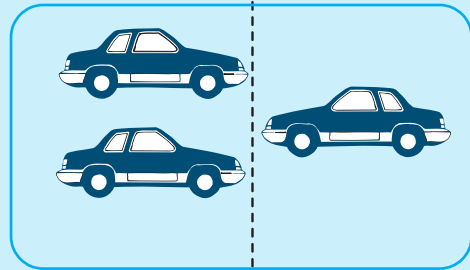

$2 + 1 = 3$
hai cộng một bằng ba

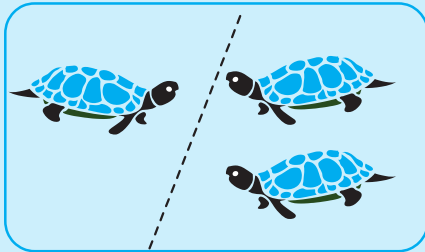

$1 + 2 = 3$
một cộng hai bằng ba

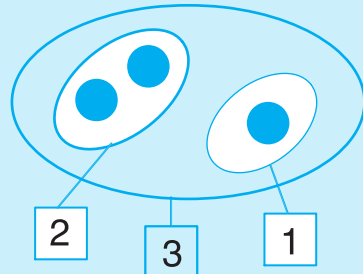

$2 + 1 = 3$
 $1 + 2 = 3$



Tính :

$1 + 1 =$

$1 + 2 =$

$2 + 1 =$



Tính :

$$\begin{array}{r} 1 \\ + 1 \\ \hline \end{array}$$

$$\begin{array}{r} 1 \\ + 2 \\ \hline \end{array}$$

$$\begin{array}{r} 2 \\ + 1 \\ \hline \end{array}$$



Nối phép tính với số thích hợp :

$1 + 2$

$1 + 1$

$2 + 1$

1

2

3

LUYỆN TẬP



1 

Số ?

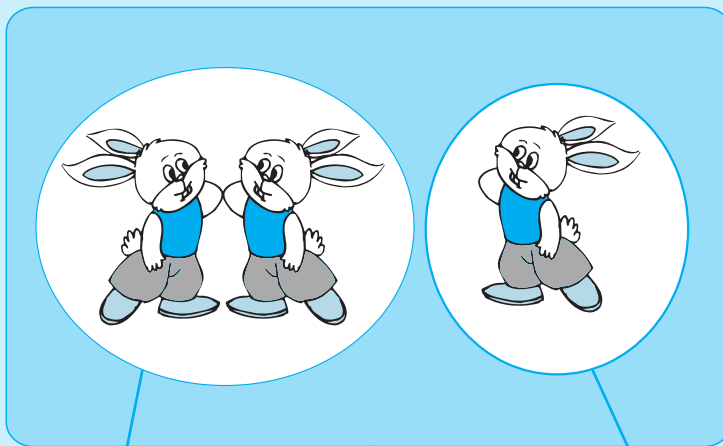

2

3

1

$$\square + \square = \square$$

$$\square + \square = \square$$

2 

Tính :

$$\begin{array}{r} 1 \\ + 1 \\ \hline \end{array}$$

$$\begin{array}{r} 2 \\ + 1 \\ \hline \end{array}$$

$$\begin{array}{r} 1 \\ + 2 \\ \hline \end{array}$$

3 

Số ?

$1 + 1 = \square$

$2 + 1 = \square$

$3 = \square + 1$

$1 + \square = 2$

$\square + 1 = 3$



$3 = 1 + \square$

$\square + 1 = 2$



$2 + \square = 3$

$1 + 2 = 2 + \square$

4  Tính :

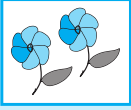
 và 
1 + 1 =

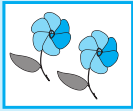
 và 
1 + 2 =

 và 
2 + 1 =

5  Viết phép tính thích hợp :

a)

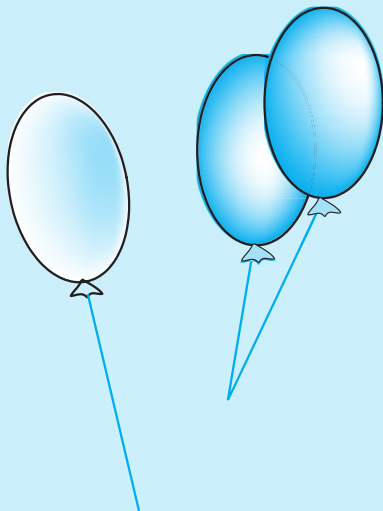

1		2	=	3
---	--	---	---	---

b)

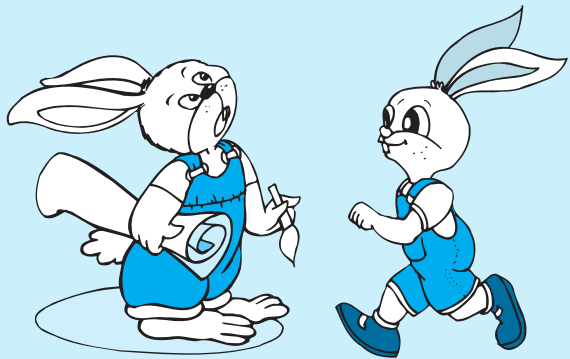

--	--	--	--	--

PHÉP CỘNG TRONG PHẠM VI 4

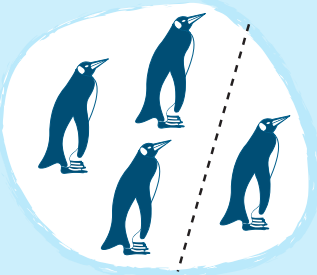

$$3 + 1 = 4$$

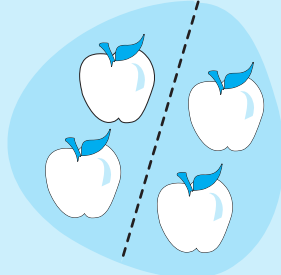

$$2 + 2 = 4$$

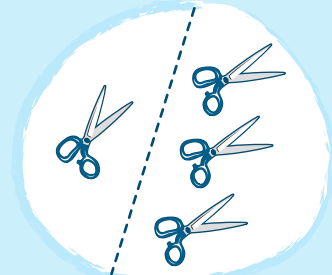

$$1 + 3 = 4$$

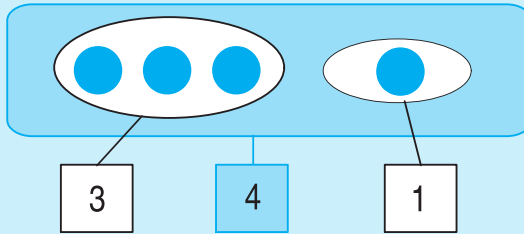

$$\begin{aligned} 3 + 1 &= 4 \\ 1 + 3 &= 4 \\ 2 + 2 &= 4 \end{aligned}$$



Tính :

$$\begin{aligned} 1 + 3 &= \\ 2 + 2 &= \end{aligned}$$

$$\begin{aligned} 3 + 1 &= \\ 2 + 1 &= \end{aligned}$$

$$\begin{aligned} 1 + 1 &= \\ 1 + 2 &= \end{aligned}$$



Tính :

$$\begin{array}{r} 2 \\ + 2 \\ \hline \end{array}$$

$$\begin{array}{r} 3 \\ + 1 \\ \hline \end{array}$$

$$\begin{array}{r} 1 \\ + 2 \\ \hline \end{array}$$

$$\begin{array}{r} 1 \\ + 3 \\ \hline \end{array}$$

$$\begin{array}{r} 1 \\ + 1 \\ \hline \end{array}$$



$$\begin{aligned} 2 + 1 &\dots 3 \\ 1 + 3 &\dots 3 \\ 1 + 1 &\dots 3 \end{aligned}$$

$$\begin{aligned} 4 &\dots 1 + 2 \\ 4 &\dots 1 + 3 \\ 4 &\dots 2 + 2 \end{aligned}$$



Viết phép tính thích hợp :

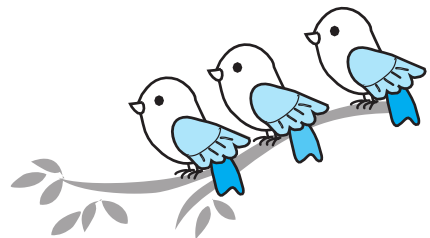



LUYỆN TẬP

1  Tính :

$$\begin{array}{r} 3 \\ + 1 \\ \hline \end{array}$$

$$\begin{array}{r} 2 \\ + 1 \\ \hline \end{array}$$

$$\begin{array}{r} 2 \\ + 2 \\ \hline \end{array}$$

$$\begin{array}{r} 1 \\ + 2 \\ \hline \end{array}$$

$$\begin{array}{r} 1 \\ + 3 \\ \hline \end{array}$$

2  Số ?

$1 \xrightarrow{+1} \boxed{2}$

$1 \xrightarrow{+2} \boxed{}$

$1 \xrightarrow{+3} \boxed{}$

$2 \xrightarrow{+2} \boxed{}$

$2 \xrightarrow{+1} \boxed{}$

$2 \xrightarrow{+2} \boxed{}$

$3 \xrightarrow{+1} \boxed{}$

$1 \xrightarrow{+3} \boxed{}$

3  Tính :

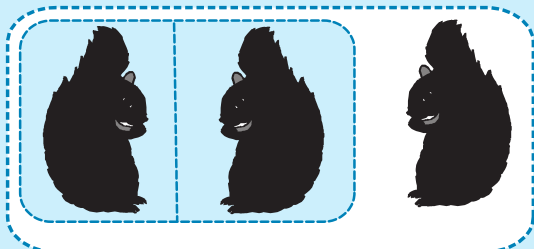

$2 + 1 + 1 =$

$1 + 2 + 1 =$

$1 + 1 + 1 = 3$

4  Viết phép tính thích hợp :

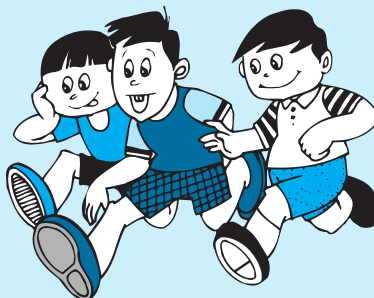

--	--	--	--	--

PHÉP CỘNG TRONG PHẠM VI 5

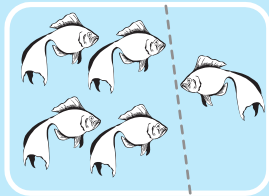

$$4 + 1 = 5$$

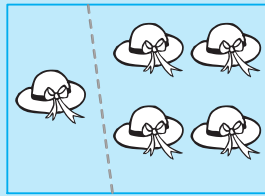

$$1 + 4 = 5$$

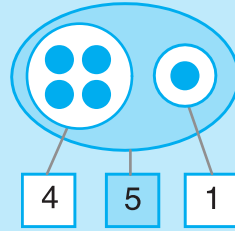

$$4 + 1 = 5$$

$$1 + 4 = 5$$

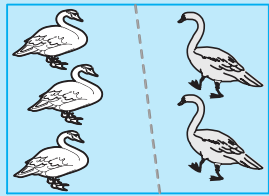

$$3 + 2 = 5$$

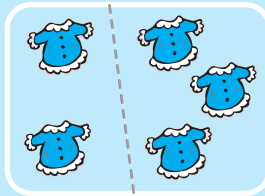

$$2 + 3 = 5$$

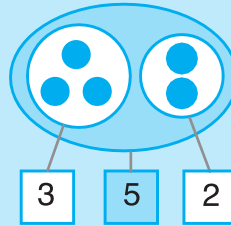

$$3 + 2 = 5$$

$$2 + 3 = 5$$



Tính :

$$4 + 1 =$$

$$3 + 2 =$$

$$2 + 3 =$$

$$1 + 4 =$$

$$2 + 2 =$$

$$2 + 3 =$$

$$4 + 1 =$$

$$3 + 1 =$$



Tính :

$$\begin{array}{r} 4 \\ + 1 \\ \hline \end{array}$$

$$\begin{array}{r} 2 \\ + 3 \\ \hline \end{array}$$

$$\begin{array}{r} 2 \\ + 2 \\ \hline \end{array}$$

$$\begin{array}{r} 3 \\ + 2 \\ \hline \end{array}$$

$$\begin{array}{r} 1 \\ + 4 \\ \hline \end{array}$$

$$\begin{array}{r} 1 \\ + 3 \\ \hline \end{array}$$



Số ?

$$4 + 1 = \dots$$

$$1 + 4 = \dots$$

$$5 = 4 + \dots$$

$$5 = 1 + \dots$$

$$3 + 2 = \dots$$

$$2 + 3 = \dots$$

$$5 = 3 + \dots$$

$$5 = 2 + \dots$$



Viết phép tính thích hợp :

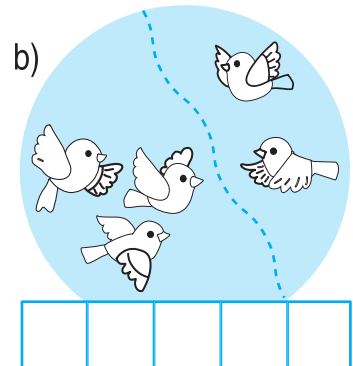
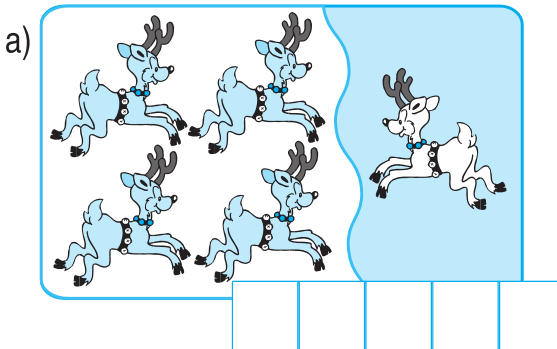



LUYỆN TẬP

1  Tính :



$1 + 1 =$	$2 + 1 =$	$3 + 1 =$	$4 + 1 =$
$1 + 2 =$	$2 + 2 =$	$3 + 2 =$	
$1 + 3 =$	$2 + 3 =$		
$1 + 4 =$		$2 + 3 = 3 + 2$	$4 + 1 = 1 + 4$

2  Tính :

$\begin{array}{r} + 2 \\ \hline 2 \end{array}$	$\begin{array}{r} + 1 \\ \hline 4 \end{array}$	$\begin{array}{r} + 3 \\ \hline 2 \end{array}$	$\begin{array}{r} + 2 \\ \hline 3 \end{array}$	$\begin{array}{r} + 4 \\ \hline 1 \end{array}$	$\begin{array}{r} + 2 \\ \hline 1 \end{array}$
--	--	--	--	--	--

3  Tính :

$2 + 1 + 1 =$	$3 + 1 + 1 =$	$1 + 2 + 2 =$
$1 + 2 + 1 =$	$1 + 3 + 1 =$	$2 + 2 + 1 =$

4  

$3 + 2 \dots 5$	$4 \dots 2 + 1$	$2 + 3 \dots 3 + 2$
$3 + 1 \dots 5$	$4 \dots 2 + 3$	$1 + 4 \dots 4 + 1$

5  Viết phép tính thích hợp :

a)

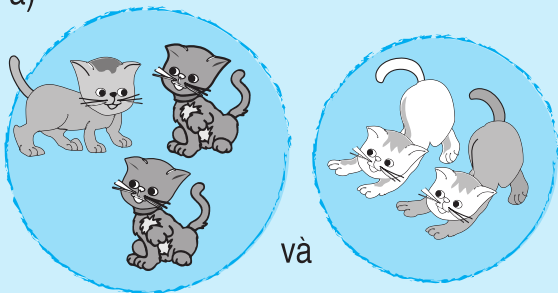

và

--	--	--	--	--

b)

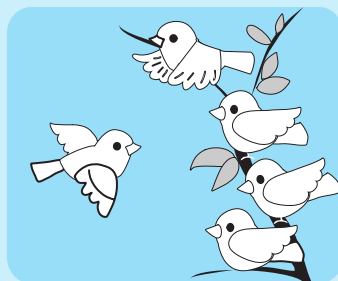

--	--	--	--	--

SỐ 0 TRONG PHÉP CỘNG

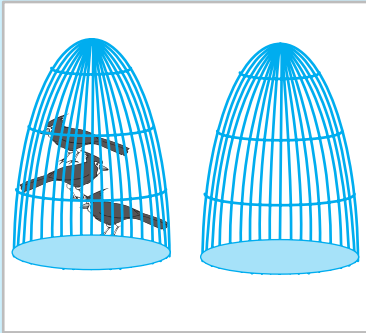

$$3 + 0 = 3$$

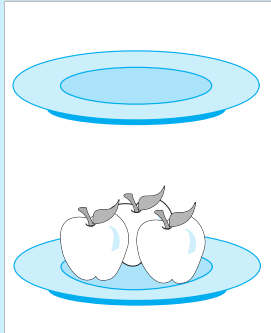

$$0 + 3 = 3$$

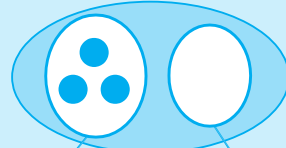

3	3	0
---	---	---

$$3 + 0 = 3$$

$$0 + 3 = 3$$

$$3 + 0 = 0 + 3$$



Tính :

$1 + 0 =$

$5 + 0 =$

$0 + 2 =$

$4 + 0 =$

$0 + 1 =$

$0 + 5 =$

$2 + 0 =$

$0 + 4 =$



Tính :

$$\begin{array}{r} 5 \\ + 0 \\ \hline \end{array}$$

$$\begin{array}{r} 3 \\ + 0 \\ \hline \end{array}$$

$$\begin{array}{r} 0 \\ + 2 \\ \hline \end{array}$$

$$\begin{array}{r} 0 \\ + 4 \\ \hline \end{array}$$

$$\begin{array}{r} 1 \\ + 0 \\ \hline \end{array}$$



Số ?

$1 + \dots = 1$

$1 + \dots = 2$

$\dots + 2 = 4$

$\dots + 3 = 3$

$2 + \dots = 2$

$0 + \dots = 0$



Viết phép tính thích hợp :

a)

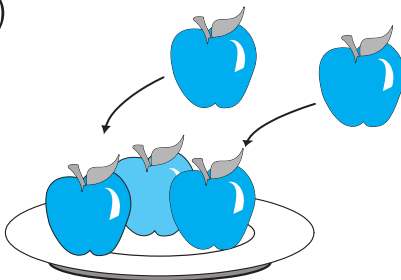

--	--	--	--	--

b)

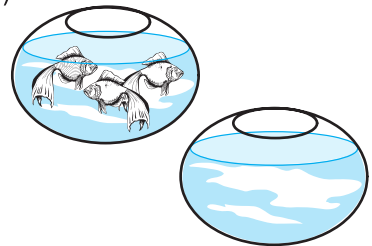

--	--	--	--	--





LUYỆN TẬP

1  Tính :

$0 + 1 =$	$0 + 2 =$	$0 + 3 =$	$0 + 4 =$
$1 + 1 =$	$1 + 2 =$	$1 + 3 =$	$1 + 4 =$
$2 + 1 =$	$2 + 2 =$	$2 + 3 =$	
$3 + 1 =$	$3 + 2 =$		
$4 + 1 =$			

2  Tính :

$1 + 2 =$	$1 + 3 =$	$1 + 4 =$	$0 + 5 =$
$2 + 1 =$	$3 + 1 =$	$4 + 1 =$	$5 + 0 =$

3   ?

$2 \dots 2 + 3$	$5 \dots 5 + 0$	$2 + 3 \dots 4 + 0$
$5 \dots 2 + 1$	$0 + 3 \dots 4$	$1 + 0 \dots 0 + 1$

4  Viết kết quả phép cộng :

Mẫu :

+	1	2
1	2	3
2	3	4

+	1	2	3
1			
2			

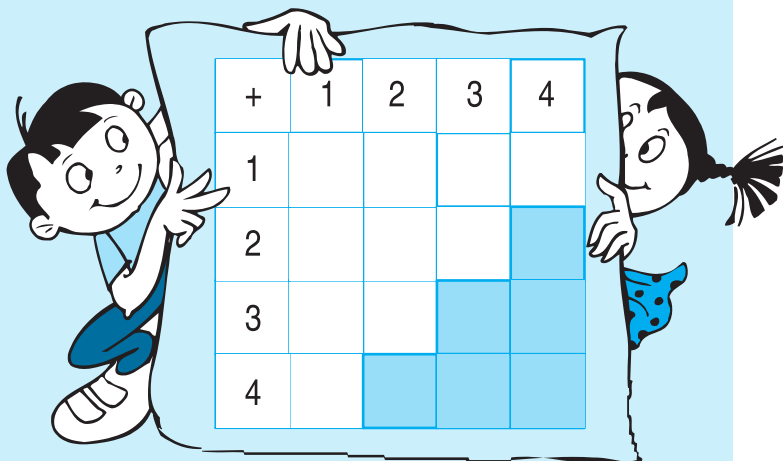

LUYỆN TẬP CHUNG



Tính :

$$\begin{array}{r} 2 \\ + 3 \\ \hline \end{array}$$

$$\begin{array}{r} 4 \\ + 0 \\ \hline \end{array}$$

$$\begin{array}{r} 1 \\ + 2 \\ \hline \end{array}$$

$$\begin{array}{r} 3 \\ + 2 \\ \hline \end{array}$$

$$\begin{array}{r} 1 \\ + 4 \\ \hline \end{array}$$

$$\begin{array}{r} 0 \\ + 5 \\ \hline \end{array}$$



Tính :

$2 + 1 + 2 =$

$3 + 1 + 1 =$

$2 + 0 + 2 =$



$2 + 3 \dots 5$

$2 + 2 \dots 1 + 2$

$1 + 4 \dots 4 + 1$

$2 + 2 \dots 5$

$2 + 1 \dots 1 + 2$

$5 + 0 \dots 2 + 3$



Viết phép tính thích hợp :

a)

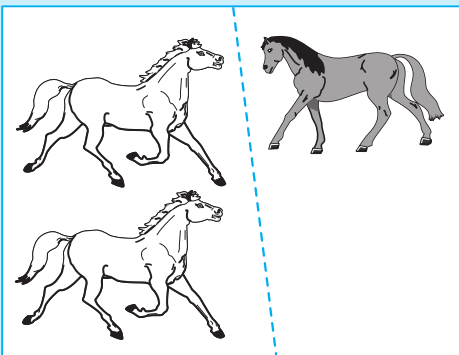

--	--	--	--	--

b)

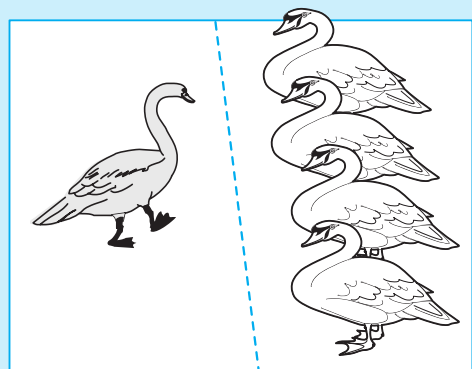

--	--	--	--	--

LUYỆN TẬP



1  **Tính :**

$1 + 2 =$	$1 + 1 =$	$1 + 2 =$	$1 + 1 + 1 =$
$1 + 3 =$	$2 - 1 =$	$3 - 1 =$	$3 - 1 - 1 =$
$1 + 4 =$	$2 + 1 =$	$3 - 2 =$	$3 - 1 + 1 =$

2  **Số ?**

$3 \xrightarrow{-1} \bigcirc$	$3 \xrightarrow{-2} \bigcirc$	$2 \xrightarrow{-1} \bigcirc$	$2 \xrightarrow{+1} \bigcirc$
-------------------------------	-------------------------------	-------------------------------	-------------------------------

3  **± ?**

$1 \dots 1 = 2$	$2 \dots 1 = 3$	$1 \dots 2 = 3$	$1 \dots 4 = 5$
$2 \dots 1 = 1$	$3 \dots 2 = 1$	$3 \dots 1 = 2$	$2 \dots 2 = 4$

4  **Viết phép tính thích hợp :**

a)



--	--	--	--	--

b)

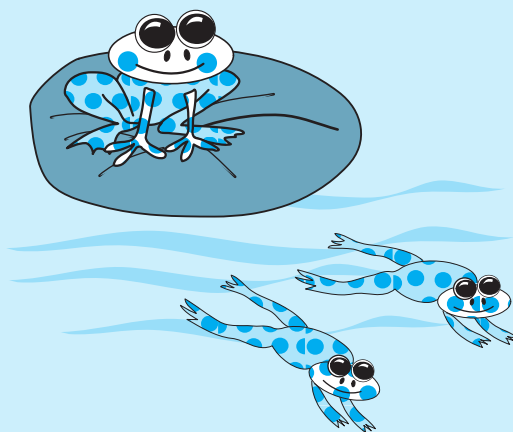

--	--	--	--	--



PHÉP TRỪ TRONG PHẠM VI 4

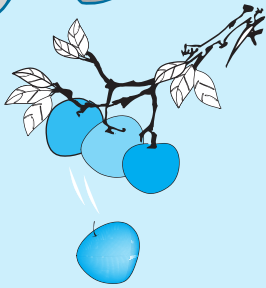

$$4 - 1 = 3$$

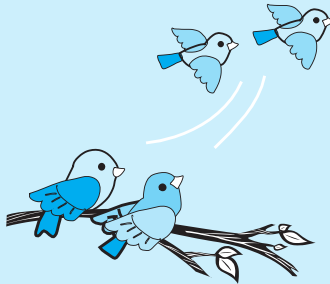

$$4 - 2 = 2$$

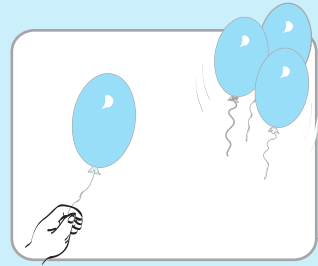

$$4 - 3 = 1$$

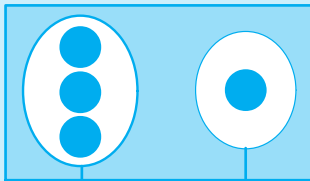

3

4

1

$$3 + 1 = 4$$

$$1 + 3 = 4$$

$$4 - 1 = 3$$

$$4 - 3 = 1$$

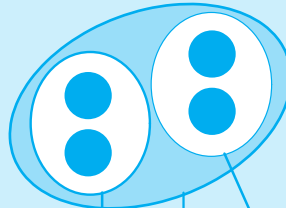

2

4

2

$$2 + 2 = 4$$

$$4 - 2 = 2$$



Tính :

$$4 - 1 =$$

$$4 - 2 =$$

$$3 + 1 =$$

$$1 + 2 =$$

$$3 - 1 =$$

$$3 - 2 =$$

$$4 - 3 =$$

$$3 - 1 =$$

$$2 - 1 =$$

$$4 - 3 =$$

$$4 - 1 =$$

$$3 - 2 =$$



Tính :

$$\begin{array}{r} 4 \\ - 2 \\ \hline \end{array}$$

$$\begin{array}{r} 4 \\ - 1 \\ \hline \end{array}$$

$$\begin{array}{r} 3 \\ - 2 \\ \hline \end{array}$$

$$\begin{array}{r} 4 \\ - 3 \\ \hline \end{array}$$

$$\begin{array}{r} 2 \\ - 1 \\ \hline \end{array}$$

$$\begin{array}{r} 3 \\ - 1 \\ \hline \end{array}$$



Viết phép tính thích hợp :



LUYỆN TẬP





1  Tính : $\begin{array}{r} 4 \\ -1 \\ \hline \end{array}$ $\begin{array}{r} 3 \\ -2 \\ \hline \end{array}$ $\begin{array}{r} 4 \\ -3 \\ \hline \end{array}$ $\begin{array}{r} 4 \\ -2 \\ \hline \end{array}$ $\begin{array}{r} 2 \\ -1 \\ \hline \end{array}$ $\begin{array}{r} 3 \\ -1 \\ \hline \end{array}$

2  Số ?

$\begin{array}{|c|} \hline 4 \\ \hline \end{array} \xrightarrow{-1} \bigcirc$ $\begin{array}{|c|} \hline 4 \\ \hline \end{array} \xrightarrow{-3} \bigcirc$ $\begin{array}{|c|} \hline 3 \\ \hline \end{array} \xrightarrow{-2} \bigcirc$ $\begin{array}{|c|} \hline 3 \\ \hline \end{array} \xrightarrow{-1} \bigcirc$

$\bigcirc \xrightarrow{+3} \bigcirc$ $\bigcirc \xrightarrow{-3} \bigcirc$ $\bigcirc \xrightarrow{-2} \bigcirc$

3  Tính : $4 - 1 - 1 =$ $4 - 1 - 2 =$ $4 - 2 - 1 =$

4   ?

$3 - 1 \dots 2$ $3 - 1 \dots 3 - 2$
 $4 - 1 \dots 2$ $4 - 3 \dots 4 - 2$
 $4 - 2 \dots 2$ $4 - 1 \dots 3 + 1$

5  Viết phép tính thích hợp :

a)

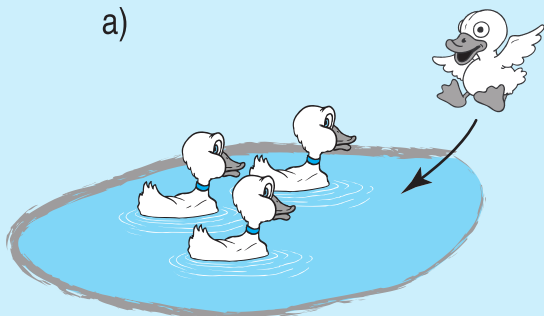

--	--	--	--	--

b)

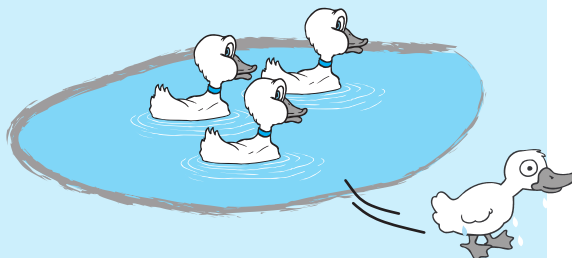

--	--	--	--	--



PHÉP TRỪ TRONG PHẠM VI 5

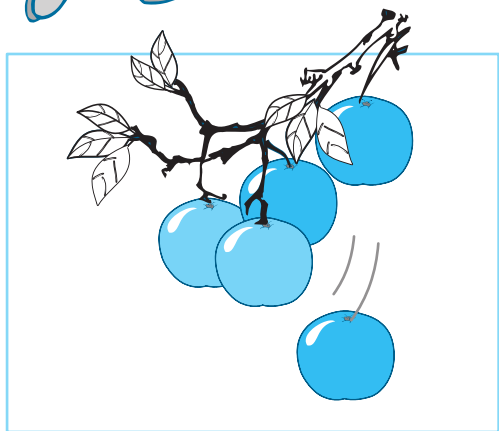

$$5 - 1 = 4$$

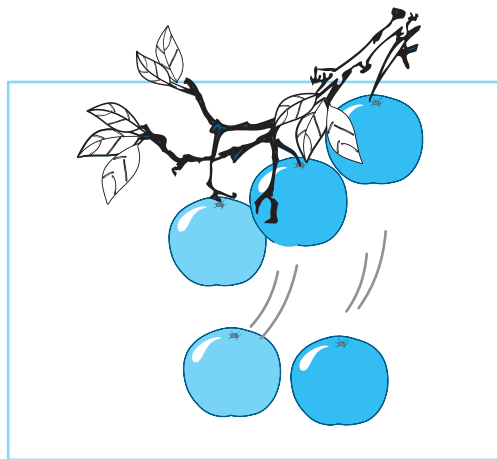

$$5 - 2 = 3$$

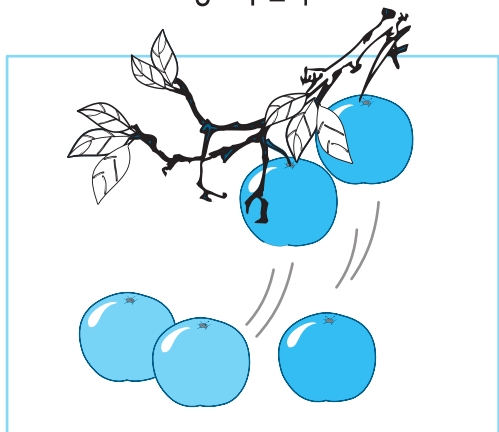

$$5 - 3 = 2$$

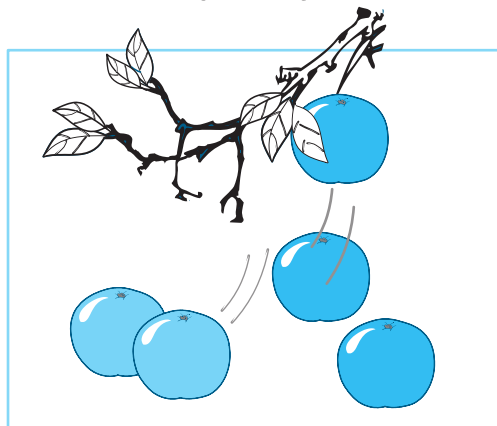

$$5 - 4 = 1$$

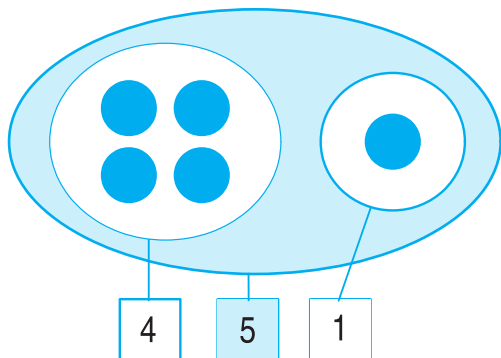

$$4 + 1 = 5$$

$$5 - 1 = 4$$

$$1 + 4 = 5$$

$$5 - 4 = 1$$

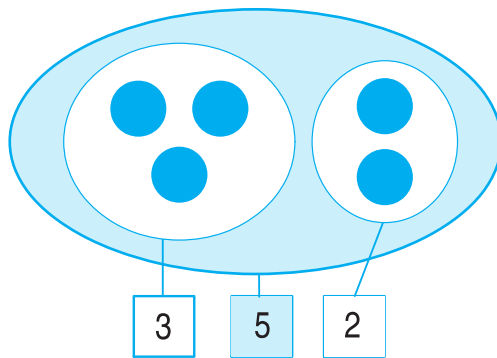

$$3 + 2 = 5$$

$$5 - 2 = 3$$

$$2 + 3 = 5$$

$$5 - 3 = 2$$



Tính :

$2 - 1 =$

$3 - 2 =$

$4 - 3 =$

$5 - 4 =$

$3 - 1 =$

$4 - 2 =$

$5 - 3 =$

$4 - 1 =$

$5 - 2 =$

$5 - 1 =$



Tính :

$5 - 1 =$

$1 + 4 =$

$2 + 3 =$

$5 - 2 =$

$4 + 1 =$

$3 + 2 =$

$5 - 3 =$

$5 - 1 =$

$5 - 2 =$

$5 - 4 =$

$5 - 4 =$

$5 - 3 =$



Tính :

$$\begin{array}{r} - 5 \\ 3 \\ \hline \end{array}$$

$$\begin{array}{r} - 5 \\ 2 \\ \hline \end{array}$$

$$\begin{array}{r} - 5 \\ 1 \\ \hline \end{array}$$

$$\begin{array}{r} - 5 \\ 4 \\ \hline \end{array}$$

$$\begin{array}{r} - 4 \\ 2 \\ \hline \end{array}$$

$$\begin{array}{r} - 4 \\ 1 \\ \hline \end{array}$$



Viết phép tính thích hợp :

a)

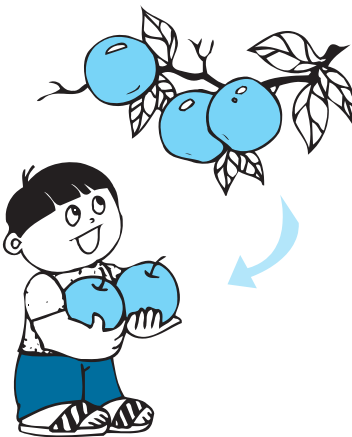

--	--	--	--	--

b)



--	--	--	--	--



LUYỆN TẬP

1  Tính :

5	4
- 2	- 1
—	—

5	3
- 4	- 2
—	—



5	4
- 3	- 2
—	—

2  Tính :

5 - 1 - 1 =
5 - 1 - 2 =

4 - 1 - 1 =
5 - 2 - 1 =

3 - 1 - 1 =
5 - 2 - 2 =

3   ?

5 - 3 ... 2
5 - 3 ... 3

5 - 4 ... 2
5 - 4 ... 1

5 - 1 ... 3
5 - 4 ... 0

4  Viết phép tính thích hợp :

a)

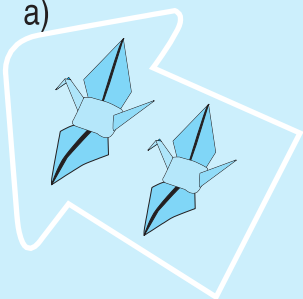

--	--	--	--	--

b)

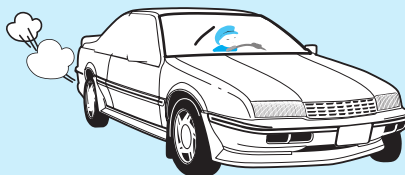

--	--	--	--	--

5  Số ? 5 - 1 = 4 + ...

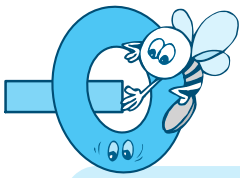

SỐ 0 TRONG PHÉP TRỪ

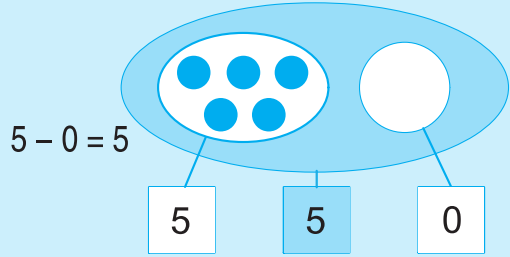
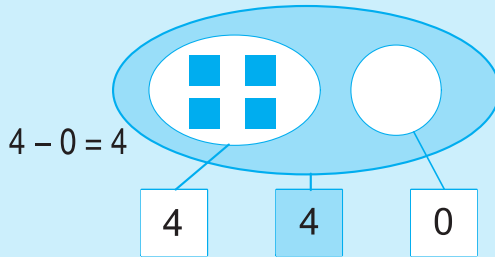
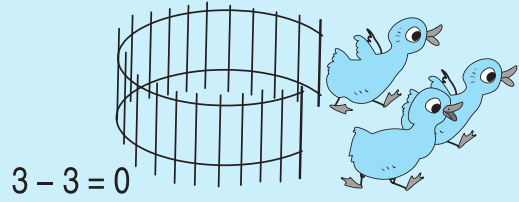
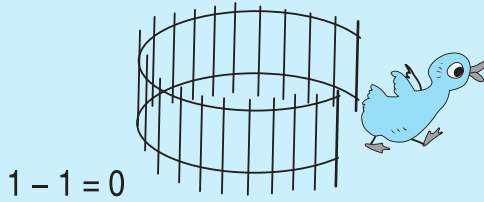

Tính :

$1 - 0 =$

$1 - 1 =$

$5 - 1 =$

$2 - 0 =$

$2 - 2 =$

$5 - 2 =$

$3 - 0 =$

$3 - 3 =$

$5 - 3 =$

$4 - 0 =$

$4 - 4 =$

$5 - 4 =$

$5 - 0 =$

$5 - 5 =$

$5 - 5 =$



Tính :

$4 + 1 =$

$2 + 0 =$

$3 + 0 =$

$4 + 0 =$

$2 - 2 =$

$3 - 3 =$

$4 - 0 =$

$2 - 0 =$

$0 + 3 =$



Viết phép tính thích hợp :

a)



--	--	--	--	--

b)

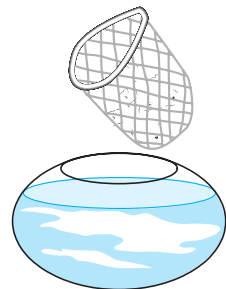



--	--	--	--	--





LUYỆN TẬP

1  Tính : $5 - 4 =$ $4 - 0 =$ $3 - 3 =$ $2 - 0 =$ $1 + 0 =$
 $5 - 5 =$ $4 - 4 =$ $3 - 1 =$ $2 - 2 =$ $1 - 0 =$

2  Tính : $\begin{array}{r} 5 \\ -1 \\ \hline \end{array}$ $\begin{array}{r} 5 \\ -0 \\ \hline \end{array}$ $\begin{array}{r} 1 \\ -1 \\ \hline \end{array}$ $\begin{array}{r} 4 \\ -2 \\ \hline \end{array}$ $\begin{array}{r} 3 \\ -3 \\ \hline \end{array}$ $\begin{array}{r} 3 \\ -0 \\ \hline \end{array}$

3  Tính : $2 - 1 - 1 =$ $3 - 1 - 2 =$ $5 - 3 - 0 =$
 $4 - 2 - 2 =$ $4 - 0 - 2 =$ $5 - 2 - 3 =$

4   $5 - 3 \dots 2$ $3 - 3 \dots 1$ $4 - 4 \dots 0$
 $5 - 1 \dots 3$ $3 - 2 \dots 1$ $4 - 0 \dots 0$

5  Viết phép tính thích hợp :

a)



--	--	--	--	--

b)

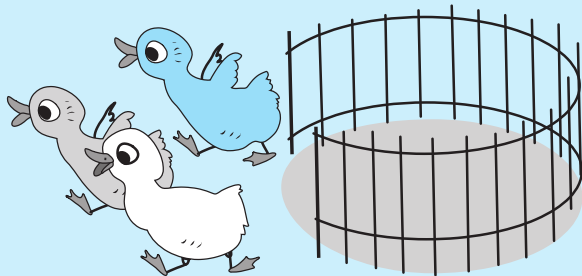

--	--	--	--	--

LUYỆN TẬP CHUNG



1  Tính :

a)
$$\begin{array}{r} -5 \\ -3 \\ \hline \end{array} \quad \begin{array}{r} +4 \\ +1 \\ \hline \end{array} \quad \begin{array}{r} +2 \\ +2 \\ \hline \end{array} \quad \begin{array}{r} -5 \\ -1 \\ \hline \end{array} \quad \begin{array}{r} -4 \\ -3 \\ \hline \end{array} \quad \begin{array}{r} +3 \\ +2 \\ \hline \end{array}$$

b)
$$\begin{array}{r} +4 \\ +0 \\ \hline \end{array} \quad \begin{array}{r} -3 \\ -3 \\ \hline \end{array} \quad \begin{array}{r} -5 \\ -0 \\ \hline \end{array} \quad \begin{array}{r} -2 \\ -2 \\ \hline \end{array} \quad \begin{array}{r} +1 \\ +0 \\ \hline \end{array} \quad \begin{array}{r} +0 \\ +1 \\ \hline \end{array}$$

2 

Tính : $2 + 3 =$ $4 + 1 =$ $1 + 2 =$ $3 + 1 =$ $4 + 0 =$
 $3 + 2 =$ $1 + 4 =$ $2 + 1 =$ $1 + 3 =$ $0 + 4 =$

3 



$4 + 1 \dots 4$ $5 - 1 \dots 0$ $3 + 0 \dots 3$
 $4 + 1 \dots 5$ $5 - 4 \dots 2$ $3 - 0 \dots 3$

4  Viết phép tính thích hợp :

a)

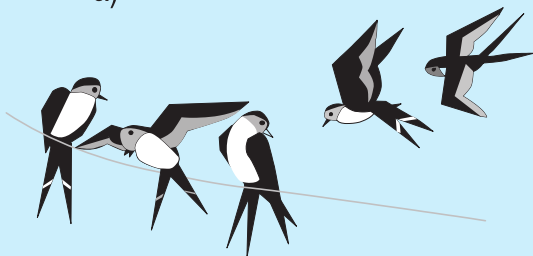

--	--	--	--	--	--

b)

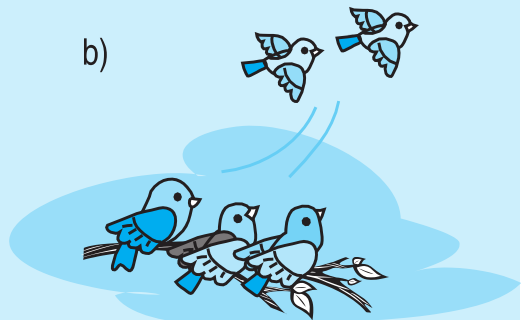

--	--	--	--	--	--



LUYỆN TẬP CHUNG



Tính : $4 + 1 =$ $5 - 2 =$ $2 + 0 =$ $3 - 2 =$ $1 - 1 =$
 $2 + 3 =$ $5 - 3 =$ $4 - 2 =$ $2 - 0 =$ $4 - 1 =$



Tính : $3 + 1 + 1 =$ $2 + 2 + 0 =$ $3 - 2 - 1 =$
 $5 - 2 - 2 =$ $4 - 1 - 2 =$ $5 - 3 - 2 =$



Số ?

$3 + \square = 5$ $4 - \square = 1$ $3 - \square = 0$
 $5 - \square = 4$ $2 + \square = 2$ $\square + 2 = 2$



Viết phép tính thích hợp :

a)

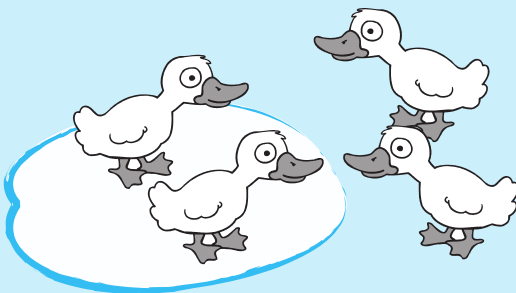

--	--	--	--	--

b)

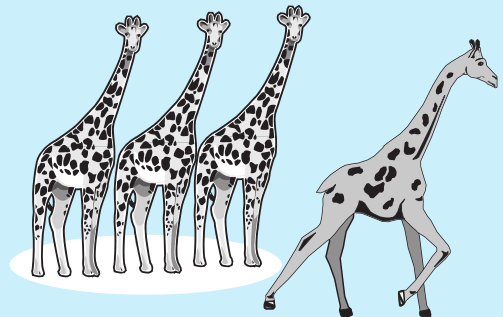

--	--	--	--	--

PHÉP CỘNG TRONG PHẠM VI 6



$5 + 1 = \dots$



$1 + 5 = \dots$

$4 + 2 = \dots$



$2 + 4 = \dots$

$3 + 3 = \dots$



$3 + 3 = \dots$



Tính :

$$\begin{array}{r} 5 \\ + 1 \\ \hline \end{array}$$

$$\begin{array}{r} 2 \\ + 4 \\ \hline \end{array}$$

$$\begin{array}{r} 3 \\ + 3 \\ \hline \end{array}$$

$$\begin{array}{r} 1 \\ + 5 \\ \hline \end{array}$$

$$\begin{array}{r} 4 \\ + 2 \\ \hline \end{array}$$

$$\begin{array}{r} 0 \\ + 6 \\ \hline \end{array}$$



Tính :

$4 + 2 =$

$5 + 1 =$

$5 + 0 =$

$2 + 2 =$

$2 + 4 =$

$1 + 5 =$

$0 + 5 =$

$3 + 3 =$



Tính :

$4 + 1 + 1 =$

$5 + 1 + 0 =$

$2 + 2 + 2 =$

$3 + 2 + 1 =$

$4 + 0 + 2 =$

$3 + 3 + 0 =$



Viết phép tính thích hợp :

a)

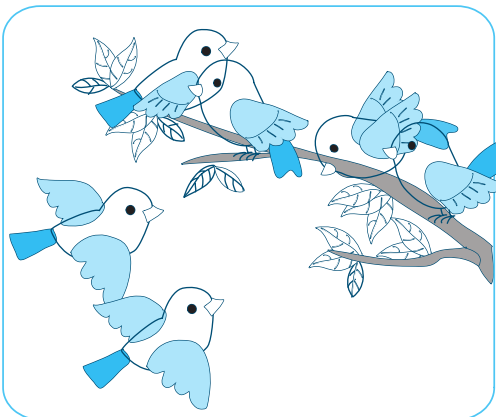

b)

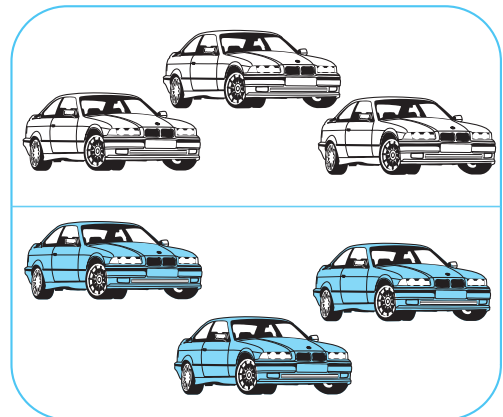



PHÉP TRỪ TRONG PHẠM VI 6

$6 - 1 = \dots$



$6 - 5 = \dots$

$6 - 2 = \dots$



$6 - 4 = \dots$

$6 - 3 = \dots$



$6 - 3 = \dots$



Tính :

$$\begin{array}{r} 6 \\ - 3 \\ \hline \end{array}$$

$$\begin{array}{r} 6 \\ - 4 \\ \hline \end{array}$$

$$\begin{array}{r} 6 \\ - 1 \\ \hline \end{array}$$

$$\begin{array}{r} 6 \\ - 5 \\ \hline \end{array}$$

$$\begin{array}{r} 6 \\ - 2 \\ \hline \end{array}$$

$$\begin{array}{r} 6 \\ - 0 \\ \hline \end{array}$$



Tính :

$5 + 1 =$

$4 + 2 =$

$3 + 3 =$

$6 - 5 =$

$6 - 2 =$

$6 - 3 =$

$6 - 1 =$

$6 - 4 =$

$6 - 6 =$



Tính :

$6 - 4 - 2 =$

$6 - 2 - 1 =$

$6 - 3 - 3 =$

$6 - 2 - 4 =$

$6 - 1 - 2 =$

$6 - 6 =$



Viết phép tính thích hợp :

a)

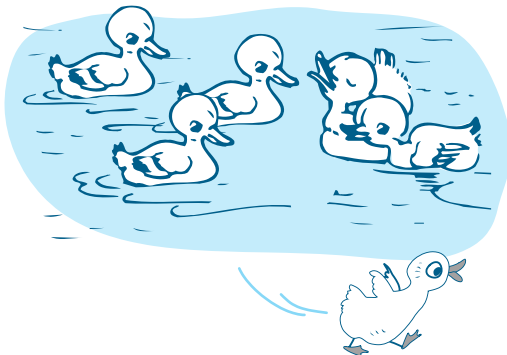

--	--	--	--	--

b)

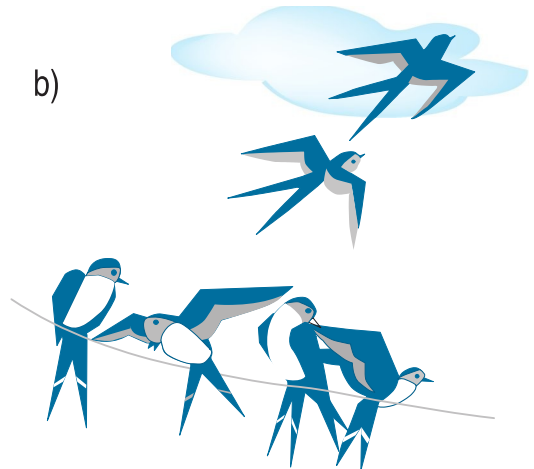

--	--	--	--	--

LUYỆN TẬP



Tính :

$$\begin{array}{r} 5 \\ + 1 \\ \hline \end{array}$$

$$\begin{array}{r} 6 \\ - 3 \\ \hline \end{array}$$

$$\begin{array}{r} 4 \\ + 2 \\ \hline \end{array}$$

$$\begin{array}{r} 6 \\ - 5 \\ \hline \end{array}$$

$$\begin{array}{r} 3 \\ + 3 \\ \hline \end{array}$$

$$\begin{array}{r} 6 \\ - 6 \\ \hline \end{array}$$

$$\begin{array}{r} 6 \\ - 2 \\ \hline \end{array}$$

$$\begin{array}{r} 0 \\ + 6 \\ \hline \end{array}$$

$$\begin{array}{r} 6 \\ - 4 \\ \hline \end{array}$$

$$\begin{array}{r} 2 \\ + 4 \\ \hline \end{array}$$

$$\begin{array}{r} 6 \\ - 0 \\ \hline \end{array}$$

$$\begin{array}{r} 6 \\ - 1 \\ \hline \end{array}$$



Tính :

$1 + 3 + 2 =$

$6 - 3 - 1 =$

$6 - 1 - 2 =$

$3 + 1 + 2 =$

$6 - 3 - 2 =$

$6 - 1 - 3 =$



?

$2 + 3 \dots 6$

$3 + 3 \dots 6$

$4 + 2 \dots 5$

$2 + 4 \dots 6$

$3 + 2 \dots 6$

$4 - 2 \dots 5$



Số ?

$\dots + 2 = 5$

$3 + \dots = 6$

$\dots + 5 = 5$

$\dots + 5 = 6$

$3 + \dots = 4$

$6 + \dots = 6$



Viết phép tính thích hợp :

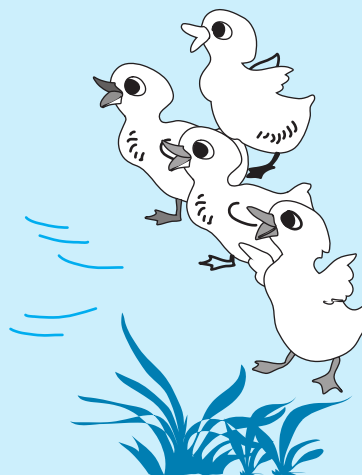
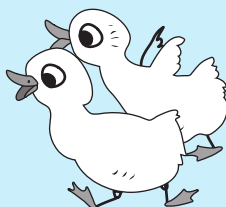

--	--	--	--	--



PHÉP CỘNG TRONG PHẠM VI 7

$6 + 1 = \dots$



$1 + 6 = \dots$

$5 + 2 = \dots$



$2 + 5 = \dots$

$4 + 3 = \dots$



$3 + 4 = \dots$



Tính :

$$\begin{array}{r} 6 \\ + 1 \\ \hline \end{array}$$

$$\begin{array}{r} 2 \\ + 5 \\ \hline \end{array}$$

$$\begin{array}{r} 4 \\ + 3 \\ \hline \end{array}$$

$$\begin{array}{r} 1 \\ + 6 \\ \hline \end{array}$$

$$\begin{array}{r} 3 \\ + 4 \\ \hline \end{array}$$

$$\begin{array}{r} 5 \\ + 2 \\ \hline \end{array}$$



Tính :

$$\begin{array}{l} 7 + 0 = \\ 0 + 7 = \end{array}$$

$$\begin{array}{l} 1 + 6 = \\ 6 + 1 = \end{array}$$

$$\begin{array}{l} 3 + 4 = \\ 4 + 3 = \end{array}$$

$$\begin{array}{l} 2 + 5 = \\ 5 + 2 = \end{array}$$



Tính :

$$\begin{array}{l} 5 + 1 + 1 = \\ 3 + 2 + 2 = \end{array}$$

$$\begin{array}{l} 4 + 2 + 1 = \\ 3 + 3 + 1 = \end{array}$$

$$\begin{array}{l} 2 + 3 + 2 = \\ 4 + 0 + 2 = \end{array}$$



Viết phép tính thích hợp :

a)

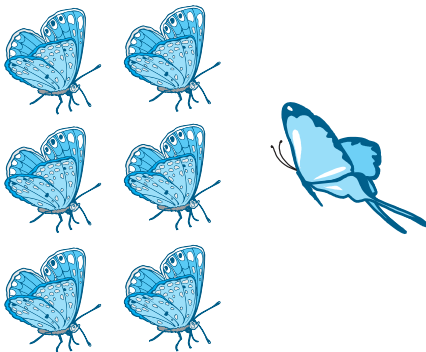

--	--	--	--	--

b)

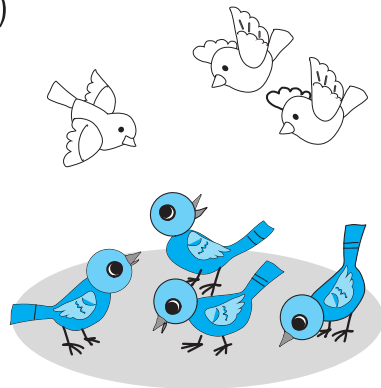

--	--	--	--	--

PHÉP TRỪ TRONG PHẠM VI 7



$7 - 1 = \dots$



$7 - 6 = \dots$

$7 - 2 = \dots$



$7 - 5 = \dots$

$7 - 3 = \dots$



$7 - 4 = \dots$



Tính :

$$\begin{array}{r} 7 \\ - 6 \\ \hline \end{array} \quad \begin{array}{r} 7 \\ - 4 \\ \hline \end{array} \quad \begin{array}{r} 7 \\ - 2 \\ \hline \end{array} \quad \begin{array}{r} 7 \\ - 5 \\ \hline \end{array} \quad \begin{array}{r} 7 \\ - 1 \\ \hline \end{array} \quad \begin{array}{r} 7 \\ - 7 \\ \hline \end{array}$$



Tính :

$$\begin{array}{l} 7 - 6 = \quad \quad \quad 7 - 3 = \quad \quad \quad 7 - 2 = \quad \quad \quad 7 - 4 = \\ 7 - 7 = \quad \quad \quad 7 - 0 = \quad \quad \quad 7 - 5 = \quad \quad \quad 7 - 1 = \end{array}$$



Tính :

$$\begin{array}{l} 7 - 3 - 2 = \quad \quad \quad 7 - 6 - 1 = \quad \quad \quad 7 - 4 - 2 = \\ 7 - 5 - 1 = \quad \quad \quad 7 - 2 - 3 = \quad \quad \quad 7 - 4 - 3 = \end{array}$$



Viết phép tính thích hợp :

a)



b)

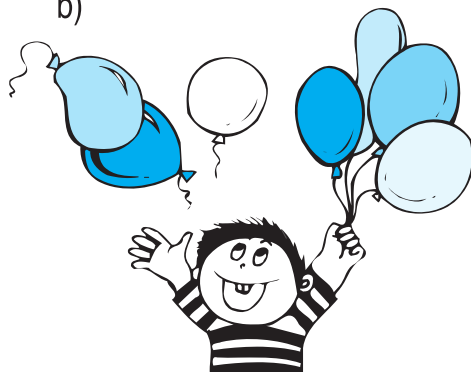



LUYỆN TẬP



Tính :

$$\begin{array}{r} 7 \\ - 3 \\ \hline \end{array}$$

$$\begin{array}{r} 2 \\ + 5 \\ \hline \end{array}$$

$$\begin{array}{r} 4 \\ + 3 \\ \hline \end{array}$$

$$\begin{array}{r} 7 \\ - 1 \\ \hline \end{array}$$

$$\begin{array}{r} 7 \\ - 0 \\ \hline \end{array}$$

$$\begin{array}{r} 7 \\ - 5 \\ \hline \end{array}$$



Tính :

$6 + 1 =$

$5 + 2 =$

$4 + 3 =$

$1 + 6 =$

$2 + 5 =$

$3 + 4 =$

$7 - 6 =$

$7 - 5 =$

$7 - 4 =$

$7 - 1 =$

$7 - 2 =$

$7 - 3 =$



Số ?

$2 + \dots = 7$

$1 + \dots = 5$

$7 - \dots = 1$

$7 - \dots = 4$

$\dots + 1 = 7$

$7 - \dots = 3$

$\dots + 3 = 7$

$\dots + 2 = 7$

$\dots - 0 = 7$



$3 + 4 \dots 7$

$5 + 2 \dots 6$

$7 - 5 \dots 3$

$7 - 4 \dots 4$

$7 - 2 \dots 5$

$7 - 6 \dots 1$



Viết phép tính thích hợp :



--	--	--	--	--

PHÉP CỘNG TRONG PHẠM VI 8



$7 + 1 = \dots$



$1 + 7 = \dots$

$6 + 2 = \dots$



$2 + 6 = \dots$

$5 + 3 = \dots$



$3 + 5 = \dots$

$4 + 4 = \dots$



$4 + 4 = \dots$

1  Tính :

$$\begin{array}{r} 5 \\ + 3 \\ \hline \end{array}$$

$$\begin{array}{r} 1 \\ + 7 \\ \hline \end{array}$$

$$\begin{array}{r} 5 \\ + 2 \\ \hline \end{array}$$

$$\begin{array}{r} 4 \\ + 4 \\ \hline \end{array}$$

$$\begin{array}{r} 2 \\ + 6 \\ \hline \end{array}$$

$$\begin{array}{r} 3 \\ + 4 \\ \hline \end{array}$$

2  Tính :

$1 + 7 =$

$2 + 6 =$

$3 + 5 =$

$4 + 4 =$

$7 + 1 =$

$6 + 2 =$

$5 + 3 =$

$8 + 0 =$

$7 - 3 =$

$4 + 1 =$

$6 - 3 =$

$0 + 2 =$

3 

Tính :

$$1 + 2 + 5 =$$

$$3 + 2 + 2 =$$

$$2 + 3 + 3 =$$

$$2 + 2 + 4 =$$

4 

Viết phép tính thích hợp :

a)

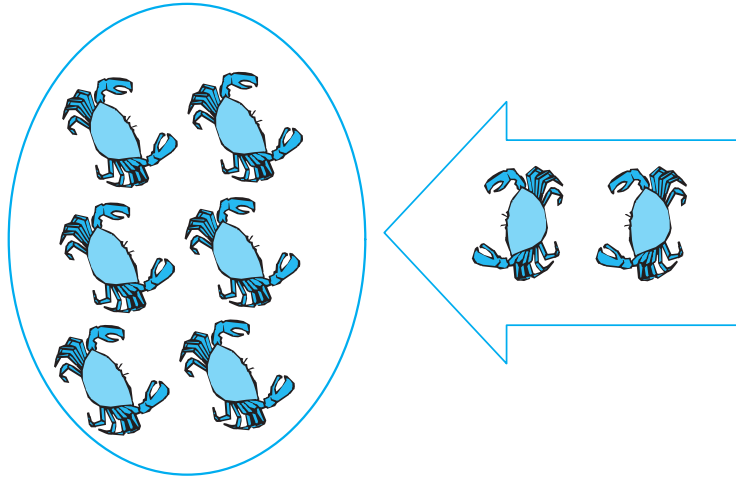

b)

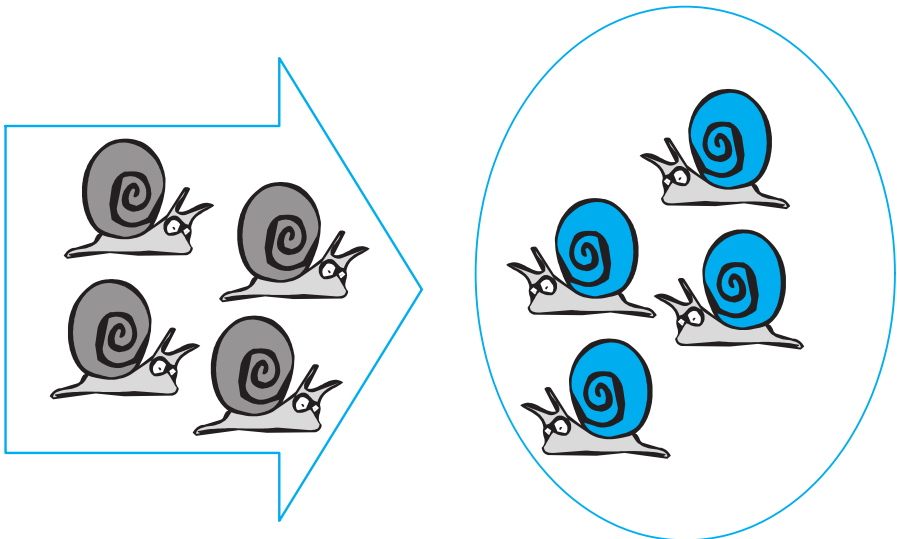

PHÉP TRỪ TRONG PHẠM VI 8



$8 - 1 = \dots$



$8 - 7 = \dots$

$8 - 2 = \dots$



$8 - 6 = \dots$

$8 - 3 = \dots$



$8 - 5 = \dots$

$8 - 4 = \dots$



$8 - 4 = \dots$

1  Tính :

$$\begin{array}{r} 8 \\ - 1 \\ \hline \end{array}$$

$$\begin{array}{r} 8 \\ - 2 \\ \hline \end{array}$$

$$\begin{array}{r} 8 \\ - 3 \\ \hline \end{array}$$

$$\begin{array}{r} 8 \\ - 4 \\ \hline \end{array}$$

$$\begin{array}{r} 8 \\ - 5 \\ \hline \end{array}$$

$$\begin{array}{r} 8 \\ - 6 \\ \hline \end{array}$$

$$\begin{array}{r} 8 \\ - 7 \\ \hline \end{array}$$

2  Tính :

$1 + 7 =$

$2 + 6 =$

$4 + 4 =$

$8 - 1 =$

$8 - 2 =$

$8 - 4 =$

$8 - 7 =$

$8 - 6 =$

$8 - 8 =$

3  Tính :

$8 - 4 =$	$8 - 5 =$	$8 - 8 =$
$8 - 1 - 3 =$	$8 - 2 - 3 =$	$8 - 0 =$
$8 - 2 - 2 =$	$8 - 1 - 4 =$	$8 + 0 =$

4  Viết phép tính thích hợp :

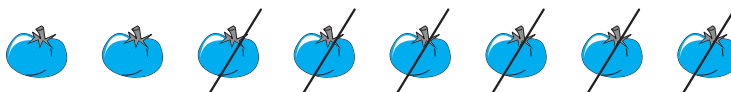

LUYỆN TẬP



1  Tính :

$7 + 1 =$	$6 + 2 =$	$5 + 3 =$	$4 + 4 =$
$1 + 7 =$	$2 + 6 =$	$3 + 5 =$	$8 - 4 =$
$8 - 7 =$	$8 - 6 =$	$8 - 5 =$	$8 + 0 =$
$8 - 1 =$	$8 - 2 =$	$8 - 3 =$	$8 - 0 =$

2  Số ?

$5 \xrightarrow{+3} \square$	$2 \xrightarrow{+6} \square$	$8 \xrightarrow{-2} \square$
$8 \xrightarrow{-4} \square$	$8 \xrightarrow{-5} \square$	$3 \xrightarrow{+4} \square$

3  Tính :

$4 + 3 + 1 =$	$8 - 4 - 2 =$	$2 + 6 - 5 =$	$8 + 0 - 5 =$
$5 + 1 + 2 =$	$8 - 6 + 3 =$	$7 - 3 + 4 =$	$3 + 3 - 4 =$

4  Viết phép tính thích hợp :

--	--	--	--	--

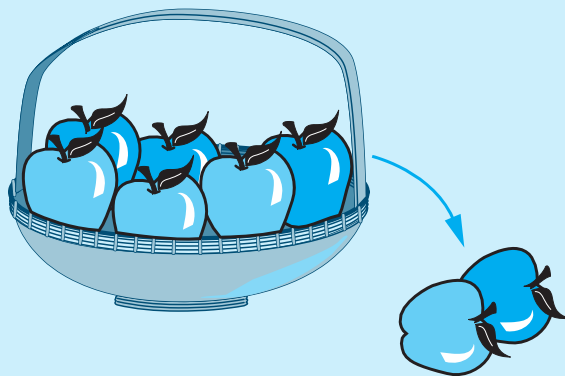

5  Nối với số thích hợp :

7

$> 5 + 2$

8

$< 8 - 0$

9

$> 8 + 0$

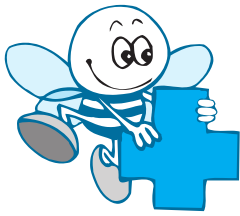

PHÉP CỘNG TRONG PHẠM VI 9

$8 + 1 = \dots$



$1 + 8 = \dots$

$7 + 2 = \dots$



$2 + 7 = \dots$

$6 + 3 = \dots$



$3 + 6 = \dots$

$5 + 4 = \dots$



$4 + 5 = \dots$

1  Tính :

$$\begin{array}{r} 1 \\ + 8 \\ \hline \end{array}$$

$$\begin{array}{r} 3 \\ + 5 \\ \hline \end{array}$$

$$\begin{array}{r} 4 \\ + 5 \\ \hline \end{array}$$

$$\begin{array}{r} 7 \\ + 2 \\ \hline \end{array}$$

$$\begin{array}{r} 6 \\ + 3 \\ \hline \end{array}$$

$$\begin{array}{r} 3 \\ + 4 \\ \hline \end{array}$$

2  Tính :

$2 + 7 =$

$4 + 5 =$

$3 + 6 =$

$8 + 1 =$

$0 + 9 =$

$4 + 4 =$

$1 + 7 =$

$5 + 2 =$

$8 - 5 =$

$7 - 4 =$

$0 + 8 =$

$6 - 1 =$

3 Tính :

$4 + 5 =$

$6 + 3 =$

$1 + 8 =$

$4 + 1 + 4 =$

$6 + 1 + 2 =$

$1 + 2 + 6 =$

$4 + 2 + 3 =$

$6 + 3 + 0 =$

$1 + 5 + 3 =$

4 Viết phép tính thích hợp :

a)

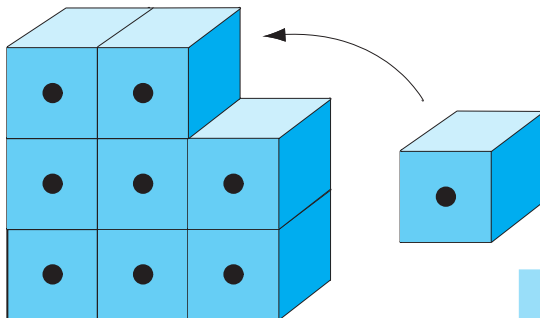

b)





PHÉP TRỪ TRONG PHẠM VI 9

$9 - 1 = \dots$  $9 - 8 = \dots$

$9 - 2 = \dots$  $9 - 7 = \dots$

$9 - 3 = \dots$  $9 - 6 = \dots$

$9 - 4 = \dots$  $9 - 5 = \dots$

1  Tính :

$$\begin{array}{r} 9 \\ - 1 \\ \hline \end{array}$$

$$\begin{array}{r} 9 \\ - 2 \\ \hline \end{array}$$

$$\begin{array}{r} 9 \\ - 3 \\ \hline \end{array}$$

$$\begin{array}{r} 9 \\ - 4 \\ \hline \end{array}$$

$$\begin{array}{r} 9 \\ - 5 \\ \hline \end{array}$$

$$\begin{array}{r} 9 \\ - 6 \\ \hline \end{array}$$

$$\begin{array}{r} 9 \\ - 7 \\ \hline \end{array}$$

$$\begin{array}{r} 9 \\ - 8 \\ \hline \end{array}$$

$$\begin{array}{r} 9 \\ - 9 \\ \hline \end{array}$$

$$\begin{array}{r} 9 \\ - 0 \\ \hline \end{array}$$



Tính :

$8 + 1 =$

$7 + 2 =$

$6 + 3 =$

$5 + 4 =$

$9 - 1 =$

$9 - 2 =$

$9 - 3 =$

$9 - 4 =$

$9 - 8 =$

$9 - 7 =$

$9 - 6 =$

$9 - 5 =$



Số ?

9	7		3		
	2	5		1	4

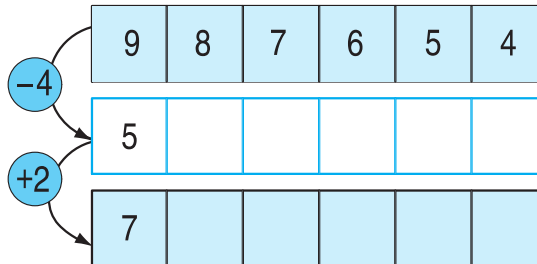

Viết phép tính thích hợp :

--	--	--	--	--

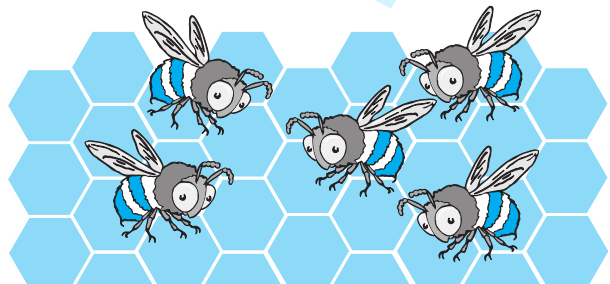
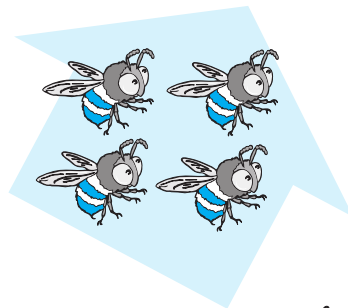





LUYỆN TẬP

1  **Tính :**

$8 + 1 =$	$7 + 2 =$	$6 + 3 =$	$5 + 4 =$
$1 + 8 =$	$2 + 7 =$	$3 + 6 =$	$4 + 5 =$
$9 - 8 =$	$9 - 7 =$	$9 - 6 =$	$9 - 5 =$
$9 - 1 =$	$9 - 2 =$	$9 - 3 =$	$9 - 4 =$

2  **Số ?**

$5 + \dots = 9$	$9 - \dots = 6$	$\dots + 6 = 9$
$4 + \dots = 8$	$7 - \dots = 5$	$\dots + 9 = 9$
$\dots + 7 = 9$	$\dots + 3 = 8$	$9 - \dots = 9$

3   **?**

$5 + 4 \dots 9$	$6 \dots 5 + 3$	$9 - 0 \dots 8$
$9 - 2 \dots 8$	$9 \dots 5 + 1$	$4 + 5 \dots 5 + 4$

4  **Viết phép tính thích hợp :**

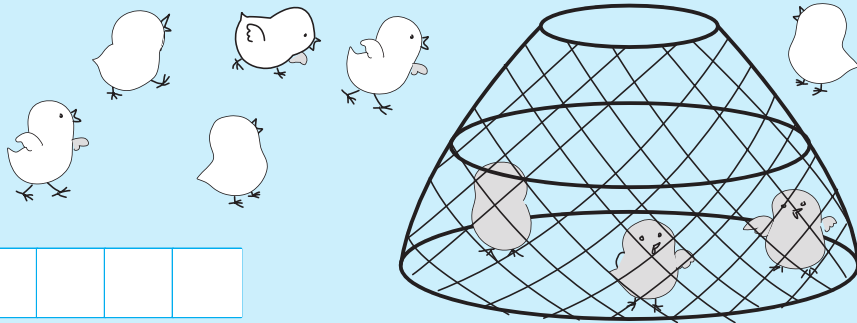

--	--	--	--	--

5  **Hình bên có mấy hình vuông ?**

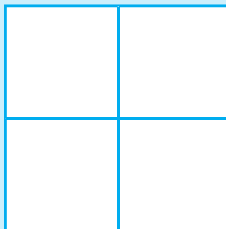

PHÉP CỘNG TRONG PHẠM VI 10



$9 + 1 = \dots$		$1 + 9 = \dots$
$8 + 2 = \dots$		$2 + 8 = \dots$
$7 + 3 = \dots$		$3 + 7 = \dots$
$6 + 4 = \dots$		$4 + 6 = \dots$
$5 + 5 = \dots$		$5 + 5 = \dots$

1 Tính :

a)
$$\begin{array}{r} 1 \\ + 9 \\ \hline \end{array}$$

$$\begin{array}{r} 2 \\ + 8 \\ \hline \end{array}$$

$$\begin{array}{r} 3 \\ + 7 \\ \hline \end{array}$$

$$\begin{array}{r} 4 \\ + 6 \\ \hline \end{array}$$

$$\begin{array}{r} 5 \\ + 5 \\ \hline \end{array}$$

$$\begin{array}{r} 9 \\ + 1 \\ \hline \end{array}$$

b) $1 + 9 =$ $2 + 8 =$ $3 + 7 =$ $4 + 6 =$
 $9 + 1 =$ $8 + 2 =$ $7 + 3 =$ $6 + 4 =$
 $9 - 1 =$ $8 - 2 =$ $7 - 3 =$ $6 - 3 =$

2 Số ?

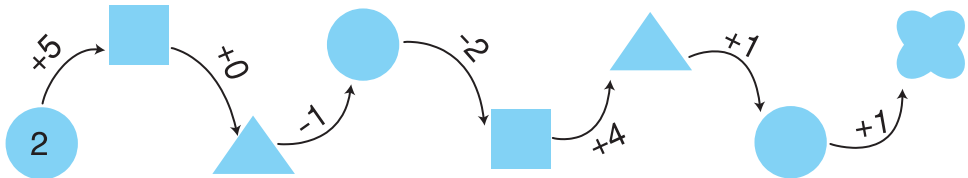

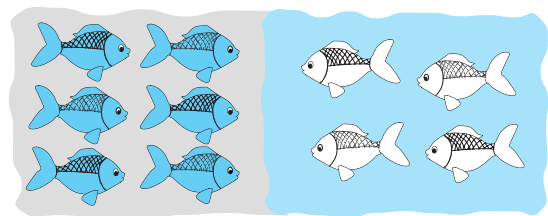

3 Viết phép tính thích hợp :







LUYỆN TẬP

1  Tính : $9 + 1 =$ $8 + 2 =$ $7 + 3 =$ $6 + 4 =$ $5 + 5 =$
 $1 + 9 =$ $2 + 8 =$ $3 + 7 =$ $4 + 6 =$ $10 + 0 =$

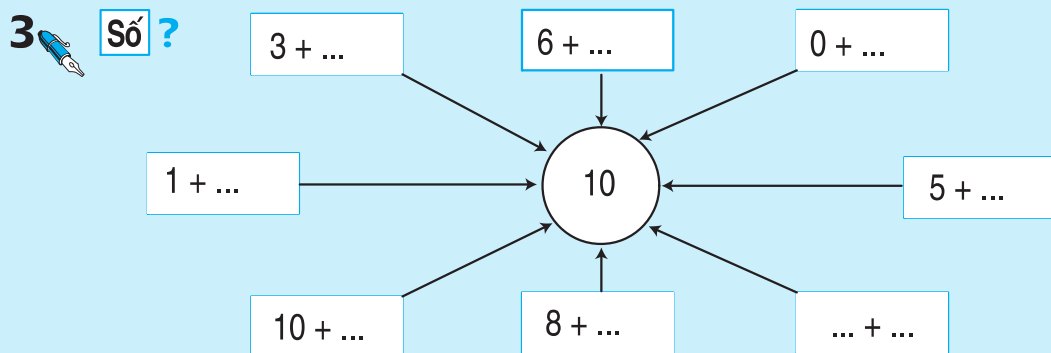
2  Tính : $\begin{array}{r} 4 \\ + 5 \\ \hline \end{array}$ $\begin{array}{r} 5 \\ + 5 \\ \hline \end{array}$ $\begin{array}{r} 8 \\ + 2 \\ \hline \end{array}$ $\begin{array}{r} 3 \\ + 7 \\ \hline \end{array}$ $\begin{array}{r} 6 \\ + 2 \\ \hline \end{array}$ $\begin{array}{r} 4 \\ + 6 \\ \hline \end{array}$



4  Tính : $5 + 3 + 2 =$ $4 + 4 + 1 =$ $6 + 3 - 5 =$ $5 + 2 - 6 =$

5  Viết phép tính thích hợp :

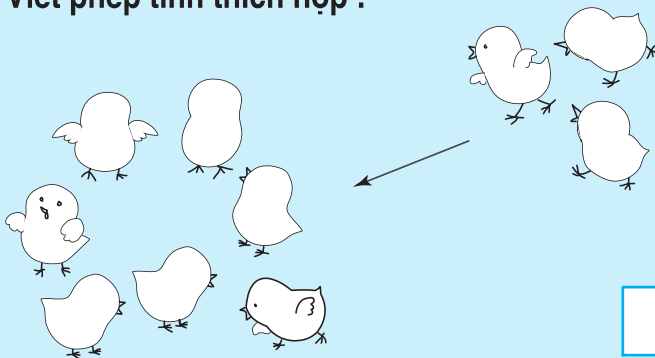

--	--	--	--	--

PHÉP TRỪ TRONG PHẠM VI 10



$10 - 1 = \dots$		$10 - 9 = \dots$
$10 - 2 = \dots$		$10 - 8 = \dots$
$10 - 3 = \dots$		$10 - 7 = \dots$
$10 - 4 = \dots$		$10 - 6 = \dots$
$10 - 5 = \dots$		$10 - 5 = \dots$

1 Tính :

a) $\begin{array}{r} 10 \\ - 1 \\ \hline \end{array}$ $\begin{array}{r} 10 \\ - 2 \\ \hline \end{array}$ $\begin{array}{r} 10 \\ - 3 \\ \hline \end{array}$ $\begin{array}{r} 10 \\ - 4 \\ \hline \end{array}$ $\begin{array}{r} 10 \\ - 5 \\ \hline \end{array}$ $\begin{array}{r} 10 \\ - 10 \\ \hline \end{array}$

b) $1 + 9 =$ $2 + 8 =$ $3 + 7 =$ $4 + 6 =$ $5 + 5 =$
 $10 - 1 =$ $10 - 2 =$ $10 - 3 =$ $10 - 4 =$ $10 - 5 =$
 $10 - 9 =$ $10 - 8 =$ $10 - 7 =$ $10 - 6 =$ $10 - 0 =$

2 Số ?

10	1	2	3	4	5	6	7	8	9	10
	9									

3



9 10

10 4

3 + 4 10

6 + 4 4

6 10 - 4

6 9 - 3

4



Viết phép tính thích hợp :

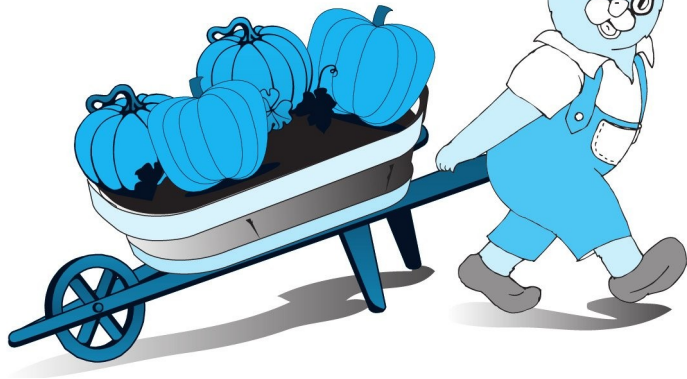
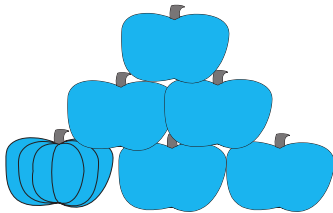

LUYỆN TẬP



1 Tính :

a) $10 - 2 =$ $10 - 4 =$ $10 - 3 =$ $10 - 7 =$ $10 - 5 =$
 $10 - 9 =$ $10 - 6 =$ $10 - 1 =$ $10 - 0 =$ $10 - 10 =$

b) $\begin{array}{r} 10 \\ - 5 \\ \hline \end{array}$ $\begin{array}{r} 10 \\ - 4 \\ \hline \end{array}$ $\begin{array}{r} 10 \\ - 8 \\ \hline \end{array}$ $\begin{array}{r} 10 \\ - 3 \\ \hline \end{array}$ $\begin{array}{r} 10 \\ - 2 \\ \hline \end{array}$ $\begin{array}{r} 10 \\ - 6 \\ \hline \end{array}$

2 Số ?

$5 + \dots = 10$

$\dots - 2 = 6$

$10 - \dots = 4$

$2 + \dots = 9$

$8 - \dots = 1$

$\dots + 0 = 10$

$10 - \dots = 8$

$4 + \dots = 7$

3 Viết phép tính thích hợp :

a)

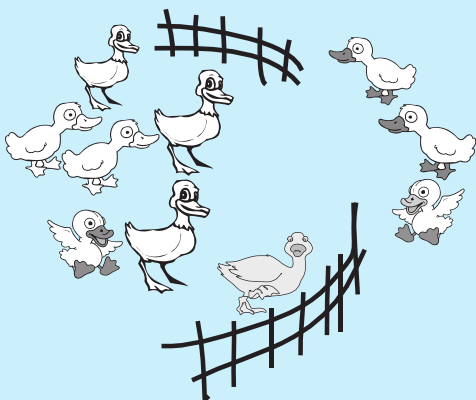

--	--	--	--	--

b)

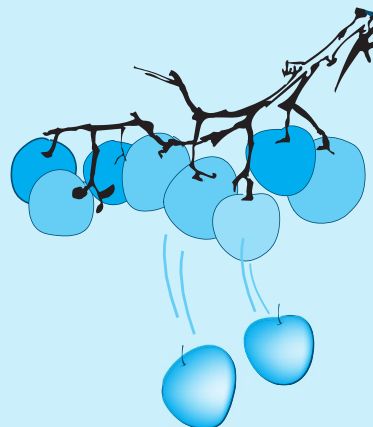

--	--	--	--	--



BẢNG CỘNG VÀ BẢNG TRỪ TRONG PHẠM VI 10

$1 + 9 = \dots$		$10 - 1 = \dots$
$2 + 8 = \dots$		$10 - 2 = \dots$
$3 + 7 = \dots$		$10 - 3 = \dots$
$4 + 6 = \dots$		$10 - 4 = \dots$
$5 + 5 = \dots$		$10 - 5 = \dots$
$6 + 4 = \dots$		$10 - 6 = \dots$
$7 + 3 = \dots$		$10 - 7 = \dots$
$8 + 2 = \dots$		$10 - 8 = \dots$
$9 + 1 = \dots$		$10 - 9 = \dots$



1 Tính :

a) $3 + 7 =$ $4 + 5 =$ $7 - 2 =$ $8 - 1 =$
 $6 + 3 =$ $10 - 5 =$ $6 + 4 =$ $9 - 4 =$

b)

$\begin{array}{r} + 5 \\ \hline 4 \end{array}$	$\begin{array}{r} - 8 \\ \hline 1 \end{array}$	$\begin{array}{r} + 5 \\ \hline 3 \end{array}$	$\begin{array}{r} - 10 \\ \hline 9 \end{array}$
$\begin{array}{r} + 2 \\ \hline 2 \end{array}$	$\begin{array}{r} - 5 \\ \hline 4 \end{array}$	$\begin{array}{r} + 3 \\ \hline 7 \end{array}$	$\begin{array}{r} - 7 \\ \hline 5 \end{array}$

2 

Số ?

10		9		8		7	
1		1			6	1	
	8		7	7			5
3		3			3		
	6		5	4		4	
5							

3 

Viết phép tính thích hợp :

a)

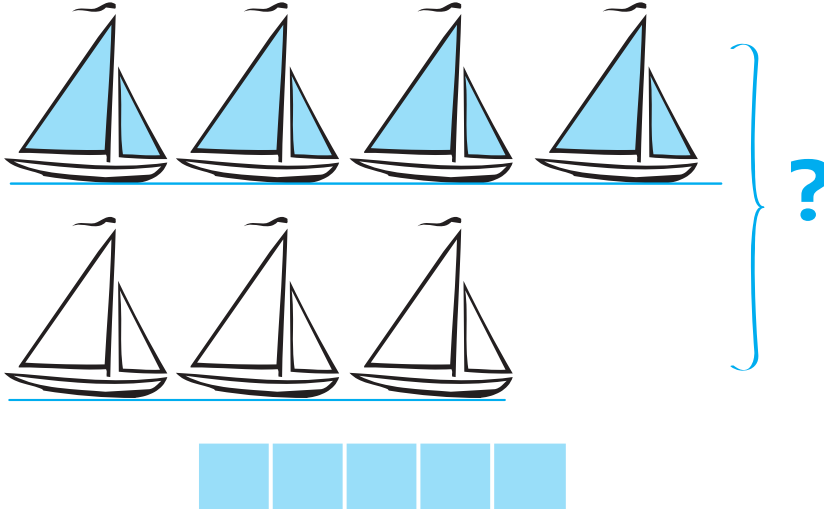

- b) Có : 10 quả bóng
 Cho : 3 quả bóng
 Còn : ... quả bóng ?





LUYỆN TẬP

1  **Tính :**

$1 + 9 =$	$2 + 8 =$	$3 + 7 =$	$4 + 6 =$	$5 + 5 =$
$10 - 1 =$	$10 - 2 =$	$10 - 3 =$	$10 - 4 =$	$10 - 5 =$
$6 + 4 =$	$7 + 3 =$	$8 + 2 =$	$9 + 1 =$	$10 + 0 =$
$10 - 6 =$	$10 - 7 =$	$10 - 8 =$	$10 - 9 =$	$10 - 0 =$

2  **Số ?**

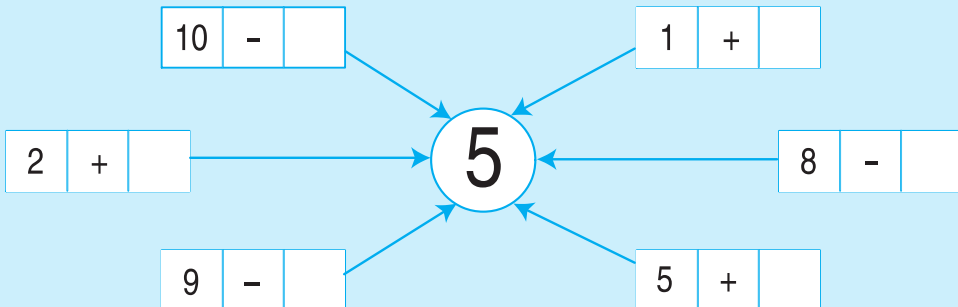
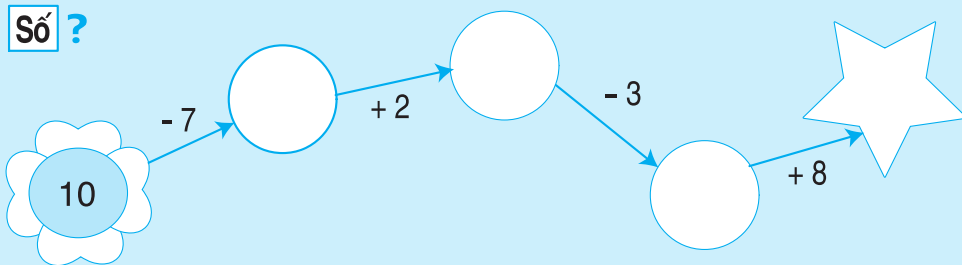

3 



10	<input type="text"/>	$3 + 4$	8	<input type="text"/>	$2 + 7$	7	<input type="text"/>	$7 - 1$
9	<input type="text"/>	$7 + 2$	10	<input type="text"/>	$1 + 9$	$2 + 2$	<input type="text"/>	$4 - 2$
$6 - 4$	<input type="text"/>	$6 + 3$	$5 + 2$	<input type="text"/>	$2 + 4$	$4 + 5$	<input type="text"/>	$5 + 4$

4  **Viết phép tính thích hợp :**

Tổ 1 : 6 bạn











Tổ 2 : 4 bạn

Cả hai tổ : ... bạn ?

LUYỆN TẬP CHUNG



1  Viết số thích hợp (theo mẫu) :

										
0	1									

2  Đọc các số từ 0 đến 10, từ 10 đến 0.

3  Tính :

$\begin{array}{r} 5 \\ + 2 \\ \hline \end{array}$	$\begin{array}{r} 4 \\ + 6 \\ \hline \end{array}$	$\begin{array}{r} 7 \\ + 1 \\ \hline \end{array}$	$\begin{array}{r} 2 \\ + 2 \\ \hline \end{array}$	$\begin{array}{r} 4 \\ + 4 \\ \hline \end{array}$	$\begin{array}{r} 10 \\ + 0 \\ \hline \end{array}$	$\begin{array}{r} 9 \\ + 1 \\ \hline \end{array}$
$\begin{array}{r} 10 \\ - 4 \\ \hline \end{array}$	$\begin{array}{r} 9 \\ - 2 \\ \hline \end{array}$	$\begin{array}{r} 8 \\ - 5 \\ \hline \end{array}$	$\begin{array}{r} 7 \\ - 6 \\ \hline \end{array}$	$\begin{array}{r} 5 \\ - 1 \\ \hline \end{array}$	$\begin{array}{r} 4 \\ - 4 \\ \hline \end{array}$	$\begin{array}{r} 3 \\ - 0 \\ \hline \end{array}$

4  Số ?



5  Viết phép tính thích hợp :

a) Có : 5 quả
 Thêm : 3 quả
 Có tất cả : ... quả ?

--	--	--	--	--

b) Có : 7 viên bi
 Bớt : 3 viên bi
 Còn : ... viên bi ?

--	--	--	--	--



LUYỆN TẬP CHUNG



Số ?

$2 = 1 + \dots$

$6 = 2 + \dots$

$8 = \dots + 3$

$10 = 8 + \dots$

$3 = 1 + \dots$

$6 = \dots + 3$

$8 = 4 + \dots$

$10 = \dots + 3$

$4 = \dots + 1$

$7 = 1 + \dots$

$9 = \dots + 1$

$10 = 6 + \dots$

$4 = 2 + \dots$

$7 = \dots + 2$

$9 = \dots + 3$

$10 = \dots + 5$

$5 = \dots + 1$

$7 = 4 + \dots$

$9 = 7 + \dots$

$10 = 10 + \dots$

$5 = 3 + \dots$

$8 = \dots + 1$

$9 = 5 + \dots$

$10 = 0 + \dots$

$6 = \dots + 1$

$8 = 6 + \dots$

$10 = \dots + 1$

$1 = 1 + \dots$



Viết các số 7, 5, 2, 9, 8 :

a) Theo thứ tự từ bé đến lớn :

b) Theo thứ tự từ lớn đến bé :



Viết phép tính thích hợp :

a)

Có :

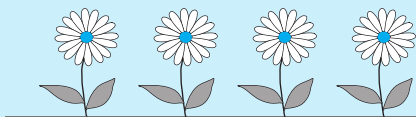

Thêm :

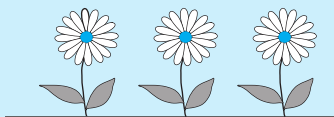

Có tất cả : ... bông hoa ?

--	--	--	--	--

b)

Có : 7 lá cờ

Bớt đi : 2 lá cờ

Còn : ... lá cờ ?

--	--	--	--	--

LUYỆN TẬP CHUNG



1  Nối các chấm theo thứ tự :

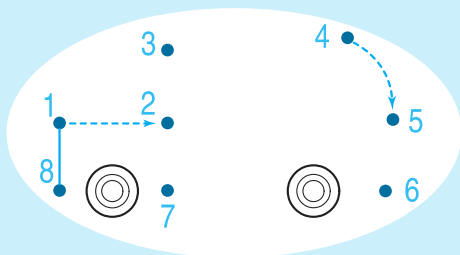
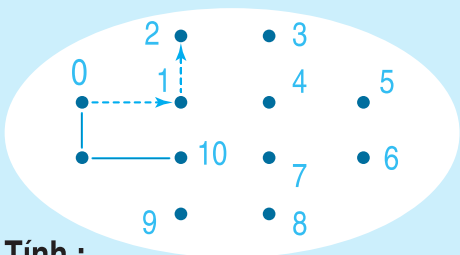

2  Tính :

a)
$$\begin{array}{r} -10 \\ \underline{\quad 5} \end{array} \quad \begin{array}{r} -9 \\ \underline{\quad 6} \end{array} \quad \begin{array}{r} +6 \\ \underline{\quad 3} \end{array} \quad \begin{array}{r} +2 \\ \underline{\quad 4} \end{array} \quad \begin{array}{r} -9 \\ \underline{\quad 5} \end{array} \quad \begin{array}{r} +5 \\ \underline{\quad 5} \end{array}$$

b) $4 + 5 - 7 =$ $6 - 4 + 8 =$ $10 - 9 + 6 =$ $9 - 4 - 3 =$
 $1 + 2 + 6 =$ $3 + 2 + 4 =$ $8 - 2 + 4 =$ $8 - 4 + 3 =$
 $3 - 2 + 9 =$ $7 - 5 + 3 =$ $3 + 5 - 6 =$ $2 + 5 - 4 =$

3 



?

$0 \dots 1$ $3 + 2 \dots 2 + 3$ $5 - 2 \dots 6 - 2$
 $10 \dots 9$ $7 - 4 \dots 2 + 2$ $7 + 2 \dots 6 + 2$

4  Viết phép tính thích hợp :

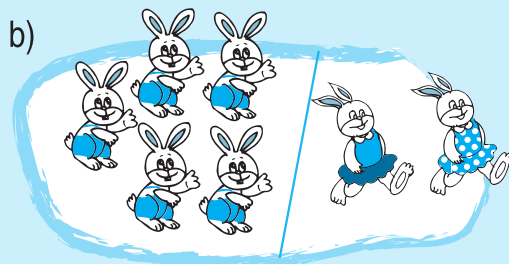
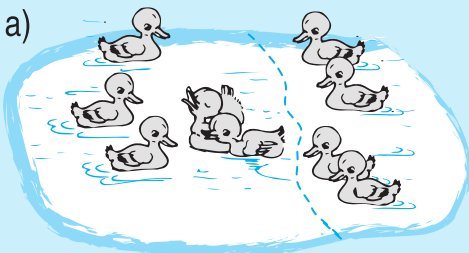

5  Xếp hình theo mẫu dưới đây :





LUYỆN TẬP CHUNG

1  Tính :

a)
$$\begin{array}{r} 4 \\ + \\ \hline 6 \end{array}$$

$$\begin{array}{r} 9 \\ - \\ \hline 2 \end{array}$$

$$\begin{array}{r} 5 \\ + \\ \hline 3 \end{array}$$

$$\begin{array}{r} 8 \\ - \\ \hline 7 \end{array}$$

$$\begin{array}{r} 2 \\ + \\ \hline 7 \end{array}$$

$$\begin{array}{r} 10 \\ - \\ \hline 8 \end{array}$$

b) $8 - 5 - 2 =$ $10 - 9 + 7 =$ $9 - 5 + 4 =$ $10 + 0 - 5 =$
 $4 + 4 - 6 =$ $2 + 6 + 1 =$ $6 - 3 + 2 =$ $7 - 4 + 4 =$

2 

Số ?

$8 = \dots + 5$

$9 = 10 - \dots$

$7 = \dots + 7$

$10 = 4 + \dots$

$6 = \dots + 5$

$2 = 2 - \dots$

3  Trong các số 6, 8, 4, 2, 10 :

a) Số nào lớn nhất ?

b) Số nào bé nhất ?

4  Viết phép tính thích hợp :

Có : 5 con cá

Thêm : 2 con cá

Có tất cả : ... con cá ?

--	--	--	--	--

5  Trong hình bên :

Có bao nhiêu hình tam giác ?



3. CÁC SỐ TRONG PHẠM VI 100. ĐO ĐỘ DÀI. GIẢI BÀI TOÁN



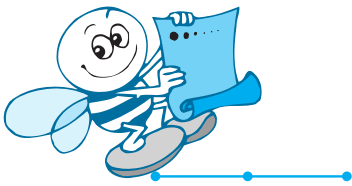

ĐIỂM. ĐOẠN THẲNG

A
•
điểm A

B
•
điểm B

A ————— B
đoạn thẳng AB

1  Đọc tên các điểm và các đoạn thẳng :

M ————— N

C ————— D

K ————— P
H ————— Q
X ————— Y

2  Dùng thước thẳng và bút để nối thành :

a) 3 đoạn thẳng

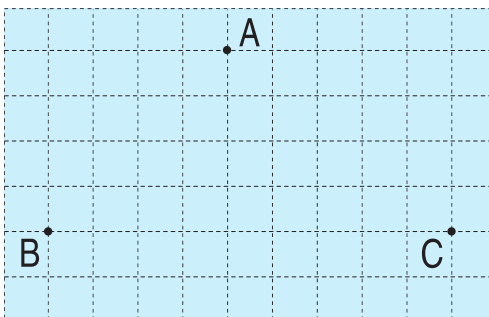

b) 4 đoạn thẳng

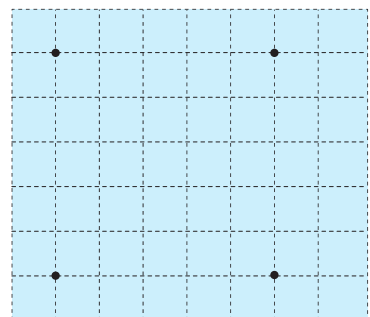

c) 5 đoạn thẳng

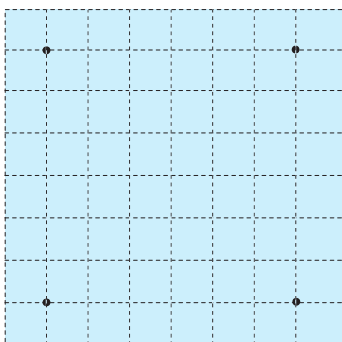

d) 6 đoạn thẳng

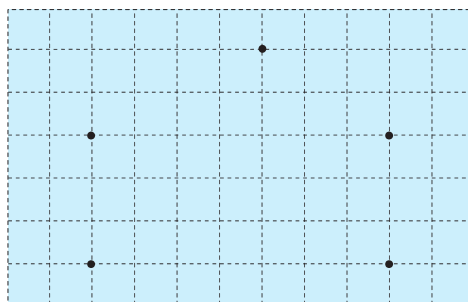

3  Mỗi hình vẽ dưới đây có bao nhiêu đoạn thẳng ?

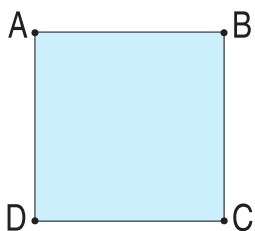

.....

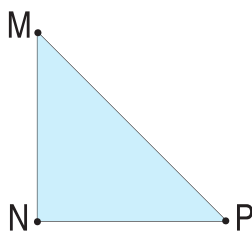

.....

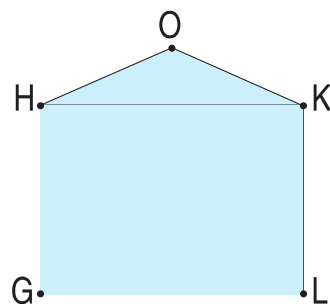

.....



ĐỘ DÀI ĐOẠN THẲNG

Dài hơn - ngắn hơn



Đo độ dài đoạn thẳng

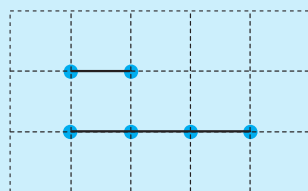
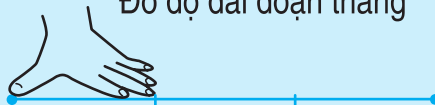

Đoạn thẳng AB ngắn hơn đoạn thẳng CD

Đoạn thẳng CD dài hơn đoạn thẳng AB

1  Đoạn thẳng nào dài hơn, đoạn thẳng nào ngắn hơn ?

a)

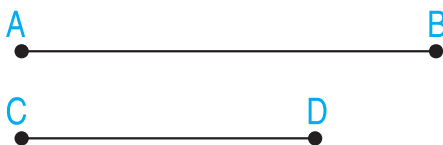

b)

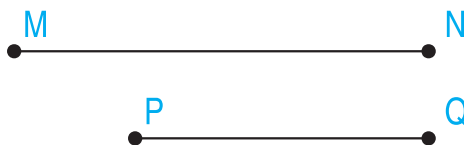

c)

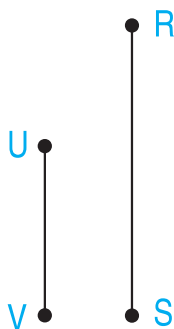

d)

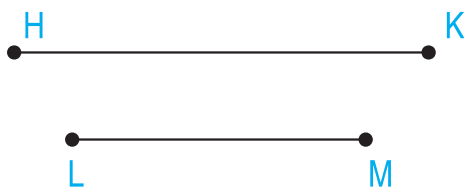

2  Ghi số thích hợp vào mỗi đoạn thẳng (theo mẫu) :

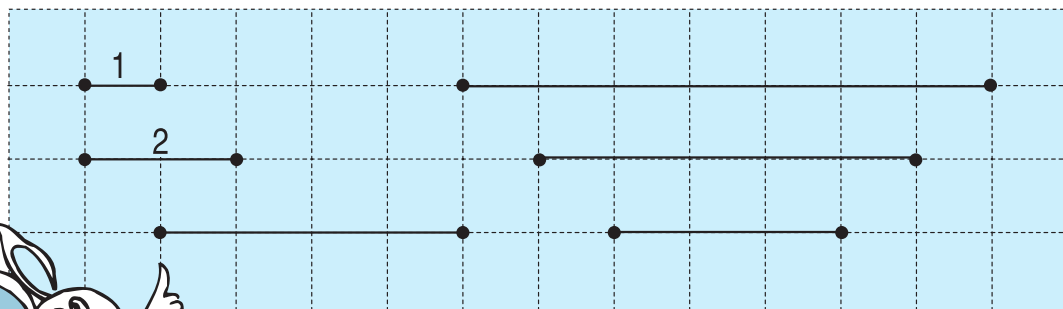

3  Tô màu vào băng giấy ngắn nhất :

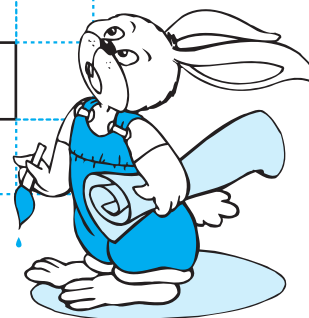
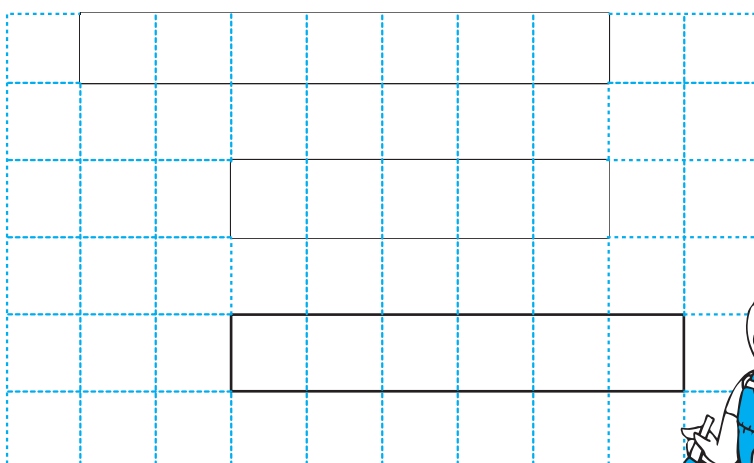



THỰC HÀNH ĐO ĐỘ DÀI

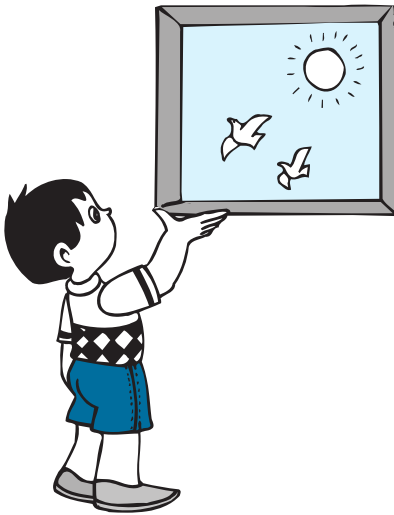

Đo độ dài bằng gang tay



Đo độ dài bằng bước chân

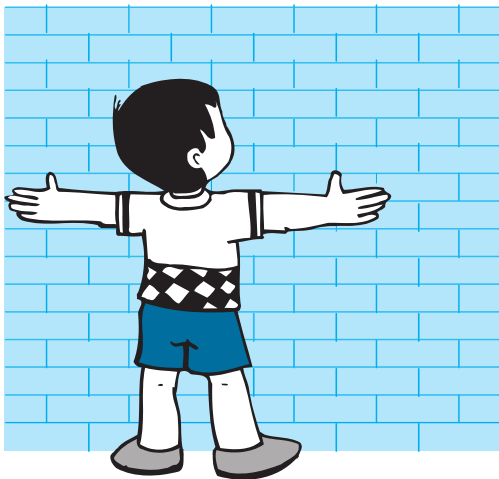

Đo độ dài bằng sải tay

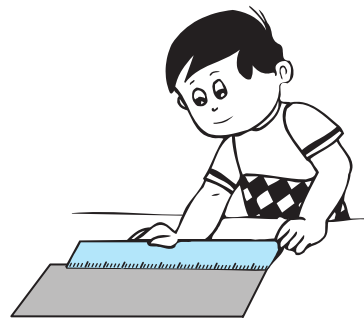

Đo độ dài bằng thước thẳng

Thực hành đo :

1. Đo độ dài bằng gang tay.
2. Đo độ dài bằng bước chân.
3. Đo độ dài bằng que tính.

MỘT CHỤC. TIA SỐ

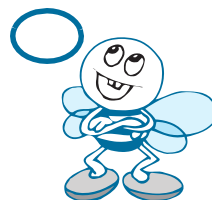
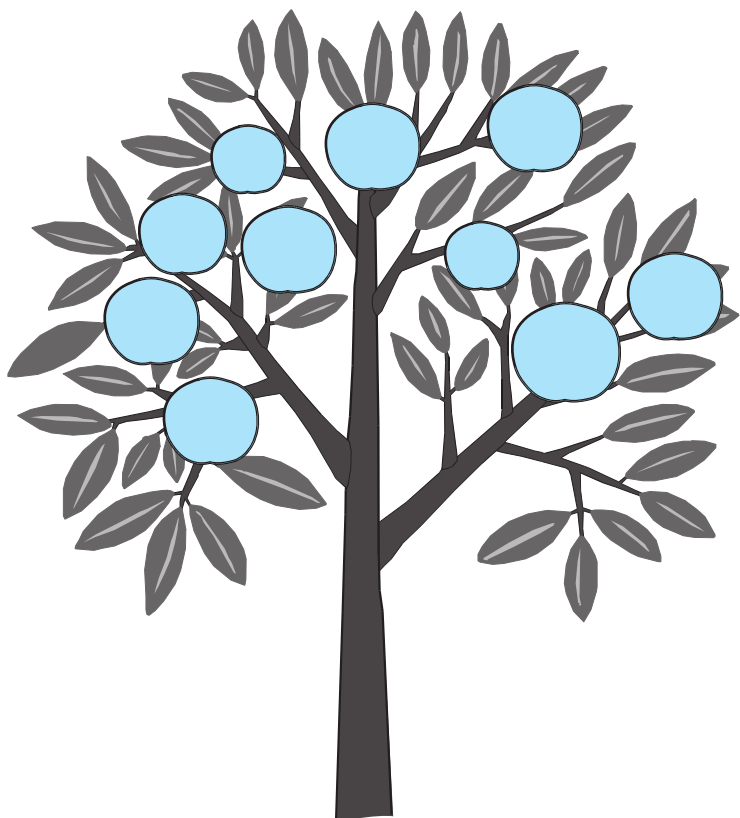
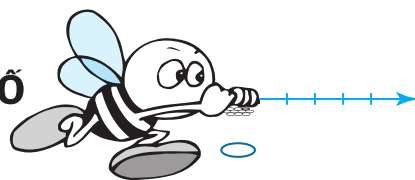

- Có 10 quả
- Có 1 chục quả

- Có 10 que tính
- Có 1 chục que tính

10 đơn vị = 1 chục

Tia số :



1  **Vẽ thêm cho đủ 1 chục chấm tròn :**

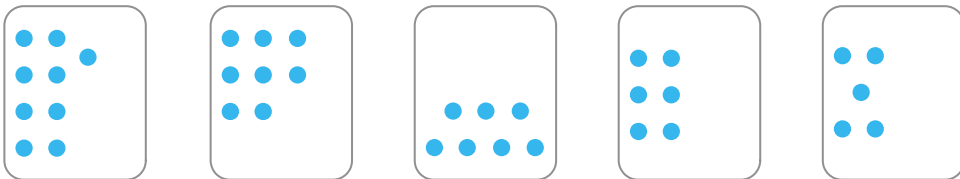

2  **Khoanh vào 1 chục con vật (theo mẫu) :**

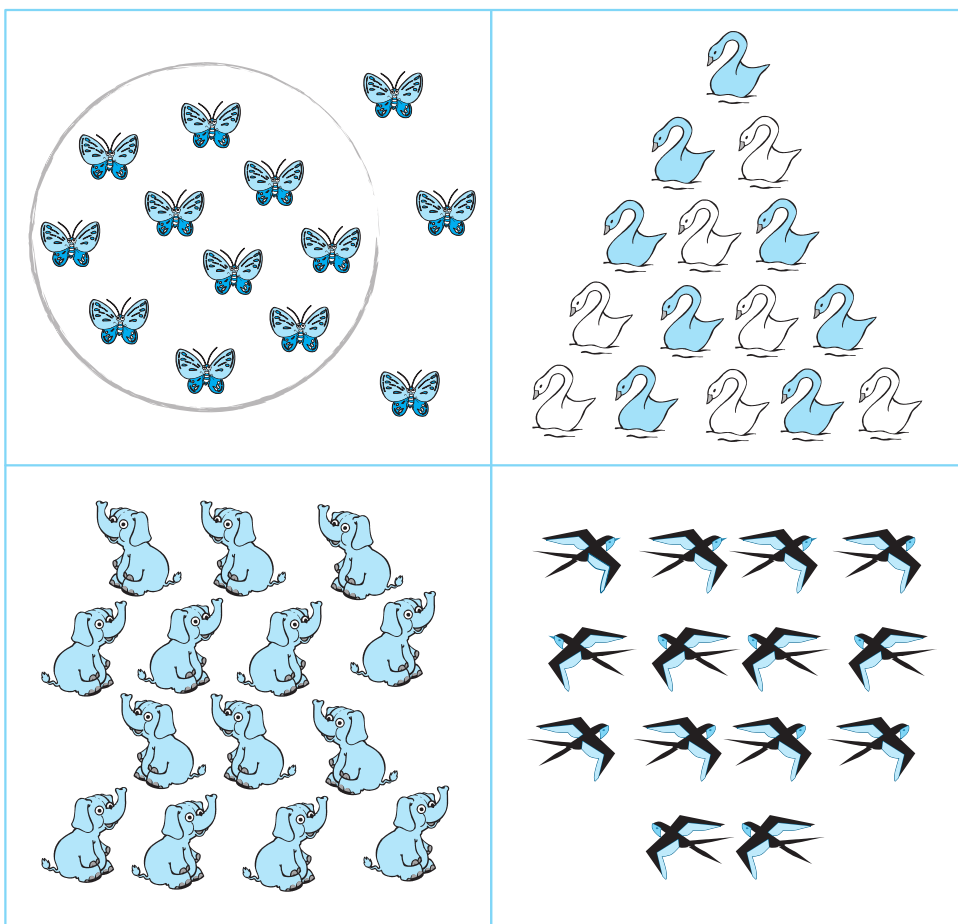

3  **Điền số vào dưới mỗi vạch của tia số :**



MƯỜI MỘT, MƯỜI HAI

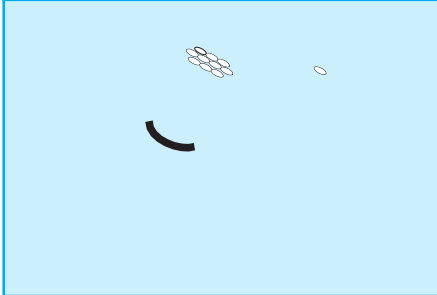
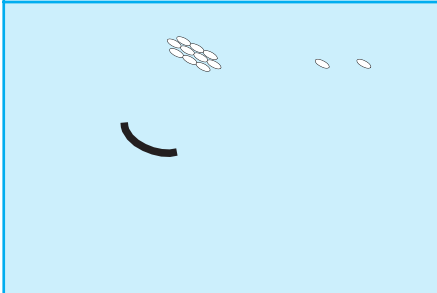

	CHỤC	ĐƠN VỊ	VIẾT SỐ	ĐỌC SỐ
	1	1	11	muời một
	1	2	12	muời hai

1  Điền số thích hợp vào ô trống :







2  **Vẽ thêm chấm tròn (theo mẫu) :**

1 chục	1 đơn vị
• •	
• •	
• •	•
• •	
• •	

1 chục	1 đơn vị
• •	
• •	
• •	
• •	
• •	

1 chục	2 đơn vị
• •	
• •	
• •	
• •	
• •	

Mẫu

3  **Tô màu 11 hình tam giác và 12 hình vuông :**

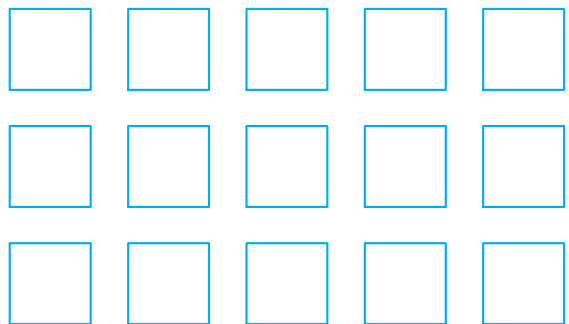
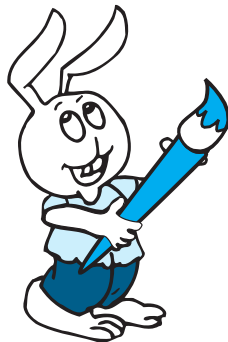
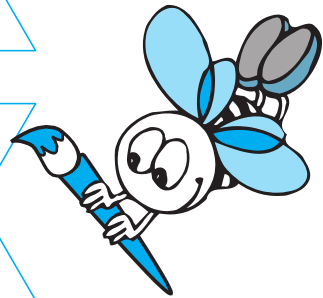
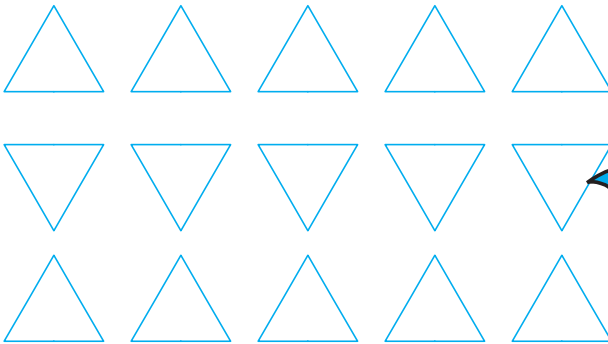

4  **Điền số vào dưới mỗi vạch của tia số :**



MƯỜI BA, MƯỜI BỐN, MƯỜI LĂM

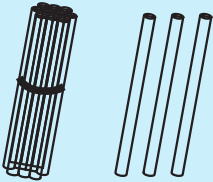
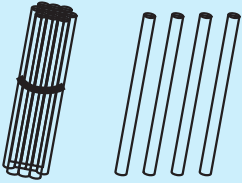
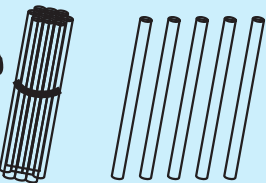

	CHỤC	ĐƠN VỊ	VIẾT SỐ	ĐỌC SỐ
	1	3	13	mười ba
	1	4	14	mười bốn
	1	5	15	mười lăm



1 Viết số :

a) Mười, mười một, mười hai, mười ba, mười bốn, mười lăm.

.....

b)

10

15

15

10



2 Điền số thích hợp vào ô trống :



3 Nói mỗi tranh với một số thích hợp (theo mẫu) :

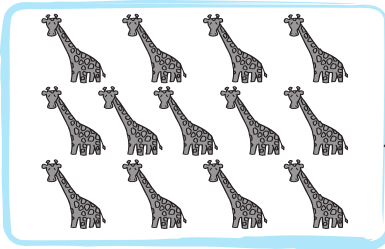

- | |
|----|
| 10 |
| 11 |
| 12 |
| 13 |
| 14 |
| 15 |

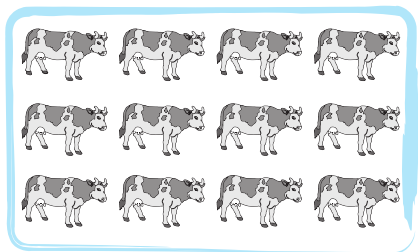
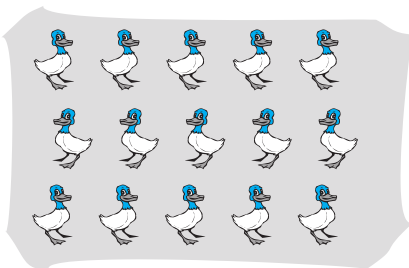
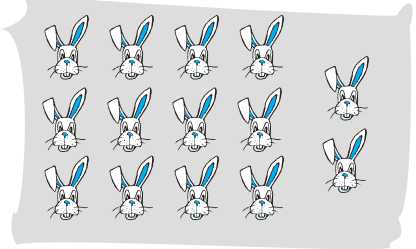

4 Điền số vào dưới mỗi vạch của tia số :



MƯỜI SÁU, MƯỜI BẢY, MƯỜI TÁM, MƯỜI CHÍN

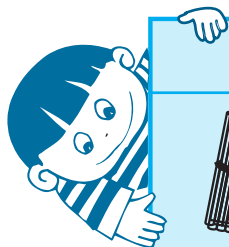

	CHỤC	ĐƠN VỊ	VIẾT SỐ	ĐỌC SỐ
	1	6	16	mười sáu
	1	7	17	mười bảy
	1	8	18	mười tám
	1	9	19	mười chín

1 Viết số :

a) Mười một, mười hai, mười ba, mười bốn, mười lăm, mười sáu, mười bảy, mười tám, mười chín.

b)

10									19
----	--	--	--	--	--	--	--	--	----

2  Điền số thích hợp vào ô trống :

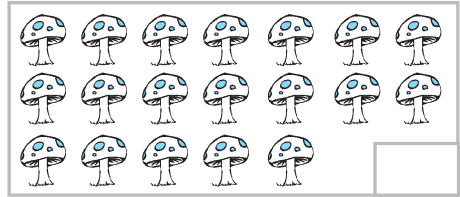
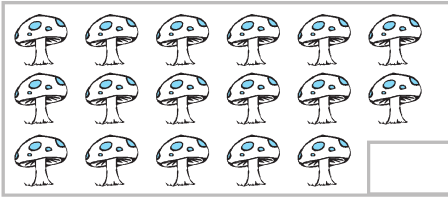
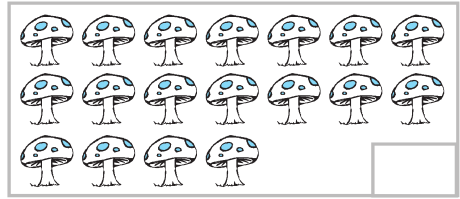
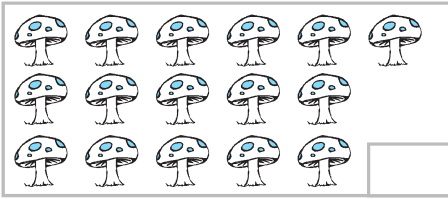

3  Nối mỗi tranh với một số thích hợp :

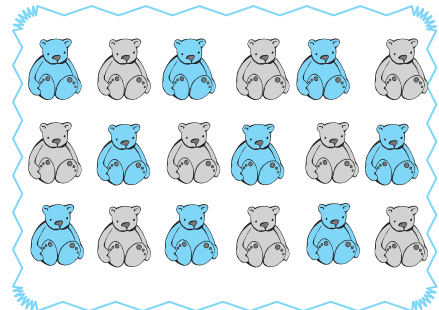
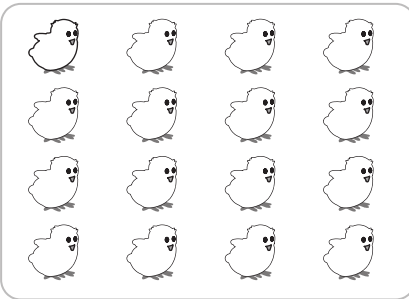

- 14
- 15
- 16
- 17
- 18
- 19

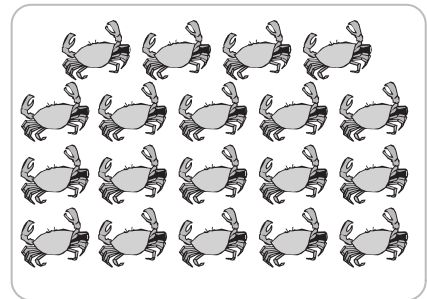

4  Điền số vào dưới mỗi vạch của tia số :



HAI MƯƠI. HAI CHỤC

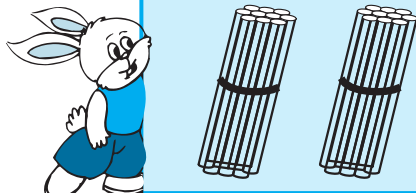

	CHỤC	ĐƠN VỊ	VIẾT SỐ	ĐỌC SỐ
	2	0	20	hai mươi

Hai mươi còn gọi là hai chục.

1  Viết các số từ 10 đến 20, từ 20 đến 10, rồi đọc các số đó :

.....
.....

2  Trả lời câu hỏi :

- Số 12 gồm mấy chục và mấy đơn vị ?
- Số 16 gồm mấy chục và mấy đơn vị ?
- Số 11 gồm mấy chục và mấy đơn vị ?
- Số 10 gồm mấy chục và mấy đơn vị ?
- Số 20 gồm mấy chục và mấy đơn vị ?

Mẫu : Số 12 gồm 1 chục và 2 đơn vị.

3  Điền số vào dưới mỗi vạch của tia số rồi đọc các số đó :



4  Trả lời câu hỏi :

- Số liền sau của 15 là số nào ?
- Số liền sau của 10 là số nào ?
- Số liền sau của 19 là số nào ?

Mẫu : Số liền sau của 15 là 16.



PHÉP CỘNG DẠNG 14 + 3

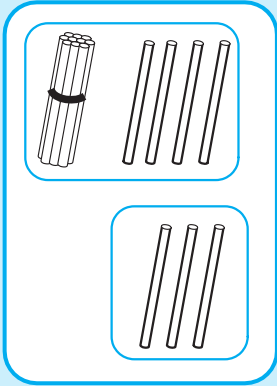

CHỤC	ĐƠN VỊ
1	4
+	3
1	7

$$\begin{array}{r} 14 \\ + 3 \\ \hline 17 \end{array}$$

- 4 cộng 3 bằng 7, viết 7
- Hạ 1, viết 1

$14 + 3 = \dots$

1  Tính :

$$\begin{array}{r} 14 \\ + 2 \\ \hline \end{array}$$

$$\begin{array}{r} 15 \\ + 3 \\ \hline \end{array}$$

$$\begin{array}{r} 13 \\ + 5 \\ \hline \end{array}$$

$$\begin{array}{r} 11 \\ + 6 \\ \hline \end{array}$$

$$\begin{array}{r} 16 \\ + 1 \\ \hline \end{array}$$

$$\begin{array}{r} 12 \\ + 7 \\ \hline \end{array}$$

$$\begin{array}{r} 17 \\ + 2 \\ \hline \end{array}$$

$$\begin{array}{r} 15 \\ + 1 \\ \hline \end{array}$$

$$\begin{array}{r} 11 \\ + 5 \\ \hline \end{array}$$

$$\begin{array}{r} 14 \\ + 4 \\ \hline \end{array}$$

2  Tính :

$12 + 3 =$

$13 + 6 =$

$12 + 1 =$

$14 + 4 =$

$12 + 2 =$

$16 + 2 =$

$13 + 0 =$

$10 + 5 =$

$15 + 0 =$

3  Điền số thích hợp vào ô trống (theo mẫu) :

14	1	2	3	4	5
	15				

13	6	5	4	3	2	1
	19					

LUYỆN TẬP



1  Đặt tính rồi tính :

$12 + 3$

$11 + 5$

$12 + 7$

$16 + 3$

$13 + 4$

$16 + 2$

$7 + 2$

$13 + 6$

2  Tính nhẩm :

$15 + 1 =$

$10 + 2 =$

$14 + 3 =$

$13 + 5 =$

$18 + 1 =$

$12 + 0 =$

$13 + 4 =$

$15 + 3 =$

3  Tính :

$10 + 1 + 3 =$

$14 + 2 + 1 =$

$11 + 2 + 3 =$

$16 + 1 + 2 =$

$15 + 3 + 1 =$

$12 + 3 + 4 =$

4  Nói (theo mẫu) :

$11 + 7$

$15 + 1$

$17 + 2$

17
19
12
16
14
18

$12 + 2$

$13 + 3$

$14 + 3$

PHÉP TRỪ DẠNG 17 - 3

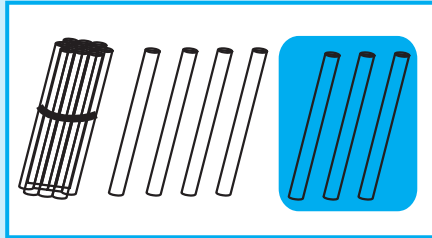

$$17 - 3 = \dots$$

CHỤC	ĐƠN VỊ
1	7
-	3
<hr/>	
1	4

$$\begin{array}{r} 17 \\ - 3 \\ \hline 14 \end{array}$$

• 7 trừ 3 bằng 4, viết 4

• Hạ 1, viết 1

1  Tính :

a) $\begin{array}{r} 13 \\ - 2 \\ \hline \end{array}$ $\begin{array}{r} 17 \\ - 5 \\ \hline \end{array}$ $\begin{array}{r} 14 \\ - 1 \\ \hline \end{array}$ $\begin{array}{r} 16 \\ - 3 \\ \hline \end{array}$ $\begin{array}{r} 19 \\ - 4 \\ \hline \end{array}$

b) $\begin{array}{r} 18 \\ - 7 \\ \hline \end{array}$ $\begin{array}{r} 18 \\ - 1 \\ \hline \end{array}$ $\begin{array}{r} 15 \\ - 4 \\ \hline \end{array}$ $\begin{array}{r} 15 \\ - 3 \\ \hline \end{array}$ $\begin{array}{r} 14 \\ - 2 \\ \hline \end{array}$

2  Tính :

$12 - 1 =$

$13 - 1 =$

$14 - 1 =$

$17 - 5 =$

$18 - 2 =$

$19 - 8 =$

$14 - 0 =$

$16 - 0 =$

$18 - 0 =$

3  Điền số thích hợp vào ô trống (theo mẫu) :

16	1	2	3	4	5
	15				

19	6	3	1	7	4
	13				

LUYỆN TẬP



1  Đặt tính rồi tính :

$14 - 3$

$17 - 5$

$19 - 2$

$16 - 5$

$17 - 2$

$19 - 7$

2  Tính nhẩm :

$14 - 1 =$

$15 - 4 =$

$17 - 2 =$

$15 - 3 =$

$15 - 1 =$

$19 - 8 =$

$16 - 2 =$

$15 - 2 =$

3  Tính :

$12 + 3 - 1 =$

$17 - 5 + 2 =$

$15 - 3 - 1 =$

$15 + 2 - 1 =$

$16 - 2 + 1 =$

$19 - 2 - 5 =$

4  Nói (theo mẫu) :

$14 - 1$

16
14
13
15
17

$19 - 3$

$15 - 1$

$17 - 5$

$17 - 2$

$18 - 1$

PHÉP TRỪ DẠNG 17 - 7

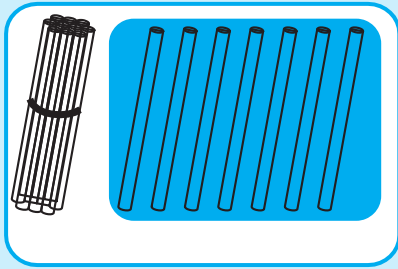

CHỤC	ĐƠN VỊ
1	7
-	7
1	0

$$\begin{array}{r}
 17 \\
 - 7 \\
 \hline
 10
 \end{array}$$

• 7 trừ 7 bằng 0, viết 0
 • Hạ 1, viết 1

$$17 - 7 = \dots$$



1 Tính :

$$\begin{array}{r}
 11 \\
 - 1 \\
 \hline
 \end{array}$$

$$\begin{array}{r}
 12 \\
 - 2 \\
 \hline
 \end{array}$$

$$\begin{array}{r}
 13 \\
 - 3 \\
 \hline
 \end{array}$$

$$\begin{array}{r}
 14 \\
 - 4 \\
 \hline
 \end{array}$$

$$\begin{array}{r}
 15 \\
 - 5 \\
 \hline
 \end{array}$$

$$\begin{array}{r}
 16 \\
 - 6 \\
 \hline
 \end{array}$$

$$\begin{array}{r}
 17 \\
 - 7 \\
 \hline
 \end{array}$$

$$\begin{array}{r}
 18 \\
 - 8 \\
 \hline
 \end{array}$$

$$\begin{array}{r}
 19 \\
 - 9 \\
 \hline
 \end{array}$$

$$\begin{array}{r}
 19 \\
 - 7 \\
 \hline
 \end{array}$$

2 Tính nhẩm :

$15 - 5 =$

$11 - 1 =$

$16 - 3 =$

$12 - 2 =$

$18 - 8 =$

$14 - 4 =$

$13 - 2 =$

$17 - 4 =$

$19 - 9 =$

3 Viết phép tính thích hợp :

Có : 15 cái kẹo

Đã ăn : 5 cái kẹo

Còn : ... cái kẹo ?



LUYỆN TẬP



1  Đặt tính rồi tính :

$13 - 3$

$14 - 2$

$10 + 6$

$19 - 9$

$11 - 1$

$17 - 7$

$16 - 6$

$10 + 9$

2  Tính nhẩm :

$10 + 3 =$

$10 + 5 =$

$17 - 7 =$

$18 - 8 =$

$13 - 3 =$

$15 - 5 =$

$10 + 7 =$

$10 + 8 =$

3  Tính :

$11 + 3 - 4 =$

$14 - 4 + 2 =$

$12 + 3 - 3 =$

$12 + 5 - 7 =$

$15 - 5 + 1 =$

$15 - 2 + 2 =$

4 



$16 - 6$

12

11

$13 - 3$

$15 - 5$

$14 - 4$

5  Viết phép tính thích hợp :

Có : 12 xe máy

Đã bán : 2 xe máy

Còn : ... xe máy ?

--	--	--	--	--



LUYỆN TẬP CHUNG

1  Điền số vào dưới mỗi vạch của tia số :

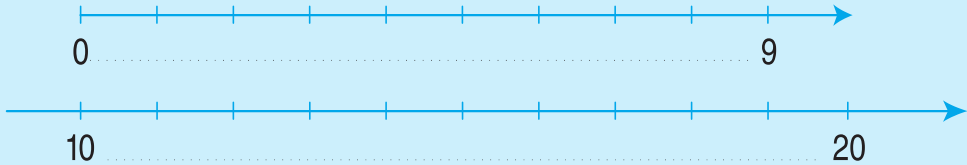

2  Trả lời câu hỏi :

- Số liền sau của 7 là số nào ?
- Số liền sau của 9 là số nào ?
- Số liền sau của 10 là số nào ?
- Số liền sau của 19 là số nào ?

Mẫu : Số liền sau của 7 là 8.

3  Trả lời câu hỏi :

- Số liền trước của 8 là số nào ?
- Số liền trước của 10 là số nào ?
- Số liền trước của 11 là số nào ?
- Số liền trước của 1 là số nào ?

Mẫu : Số liền trước của 8 là 7.



4  Đặt tính rồi tính :

$12 + 3$

$14 + 5$

$11 + 7$

$15 - 3$

$19 - 5$

$18 - 7$

5  Tính :

$11 + 2 + 3 =$

$15 + 1 - 6 =$

$17 - 5 - 1 =$

$12 + 3 + 4 =$

$16 + 3 - 9 =$

$17 - 1 - 5 =$

BÀI TOÁN CÓ LỜI VĂN

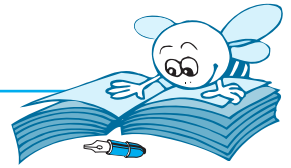

1  Viết số thích hợp vào chỗ chấm để có bài toán :

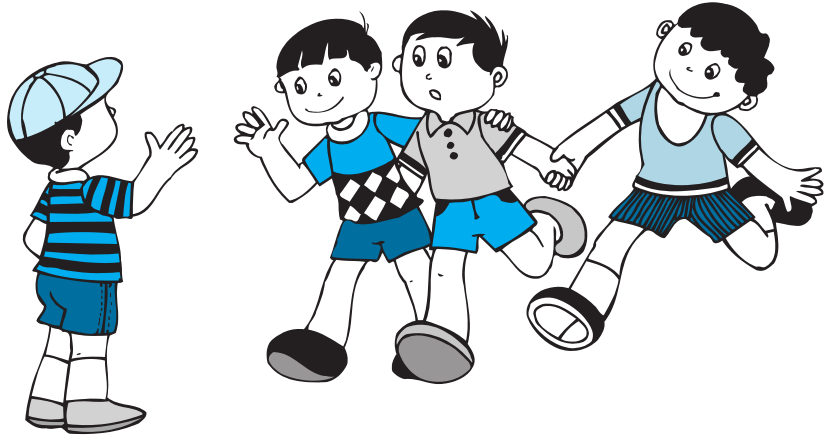

Bài toán : Có ... bạn, có thêm ... bạn đang đi tới. Hỏi có tất cả bao nhiêu bạn ?

2  Viết số thích hợp vào chỗ chấm để có bài toán :

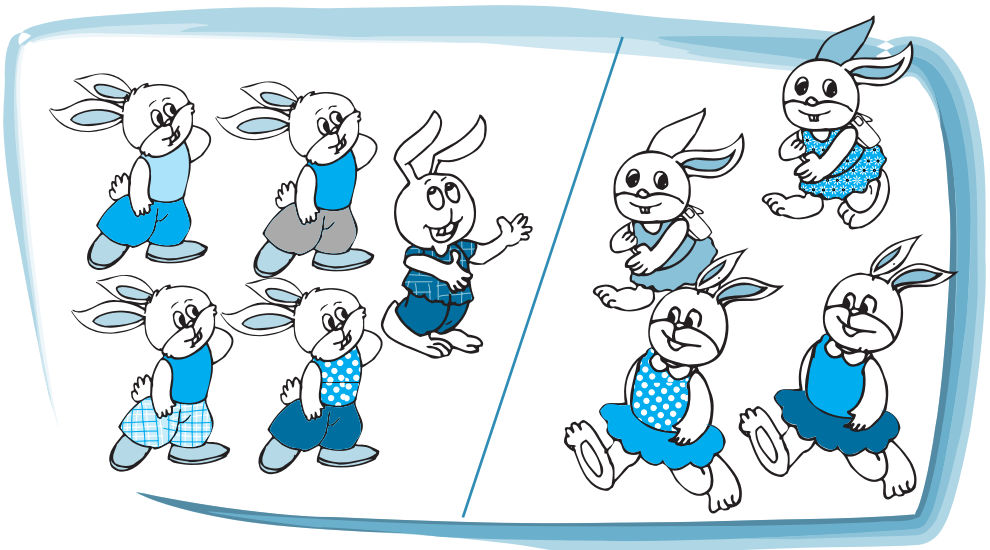

Bài toán : Có ... con thỏ, có thêm ... con thỏ đang chạy tới. Hỏi có tất cả bao nhiêu con thỏ ?

3  Viết tiếp câu hỏi để có bài toán :

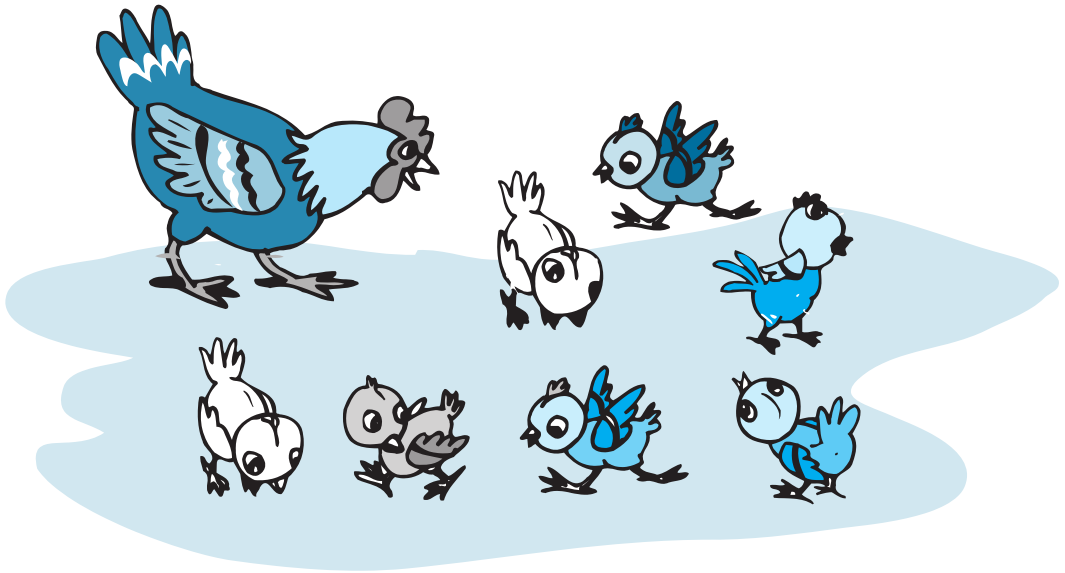

Bài toán : Có 1 gà mẹ và có 7 gà con.

Hỏi

4  Nhìn tranh vẽ, viết tiếp vào chỗ chấm để có bài toán :

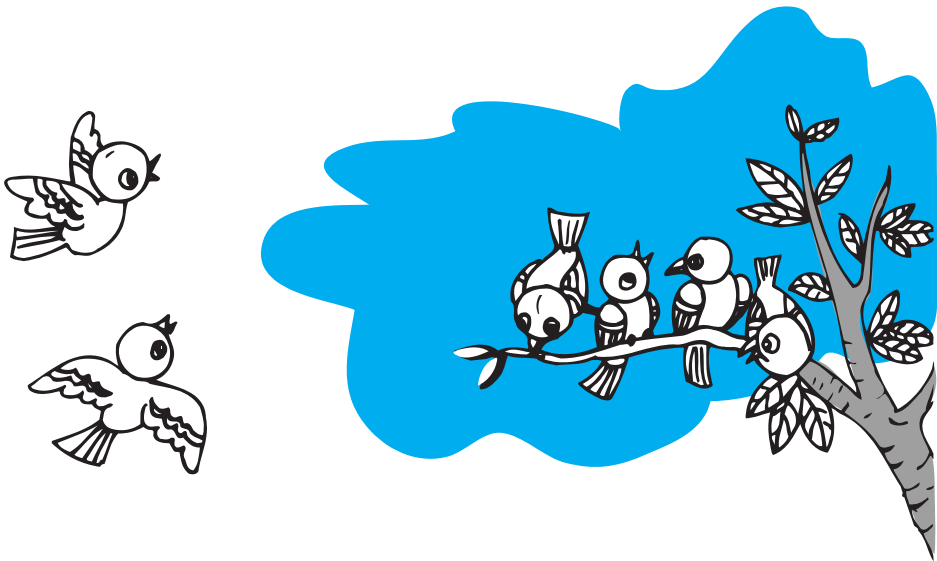

Bài toán : Có ... con chim đậu trên cành, có thêm ... con chim bay đến.

Hỏi

2  Lúc đầu tổ em có 6 bạn, sau đó có thêm 3 bạn nữa. Hỏi tổ em có tất cả mấy bạn ?



Tóm tắt

Có : ... bạn
Thêm : ... bạn
Có tất cả : ... bạn ?

Bài giải

.....
.....

Đáp số : ... bạn.

3  Đàn vịt có 5 con ở dưới ao và 4 con ở trên bờ. Hỏi đàn vịt có tất cả mấy con ?

Tóm tắt

Dưới ao : ... con vịt
Trên bờ : ... con vịt
Có tất cả : ... con vịt ?

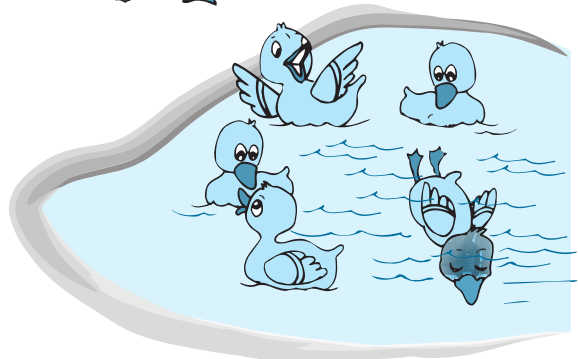
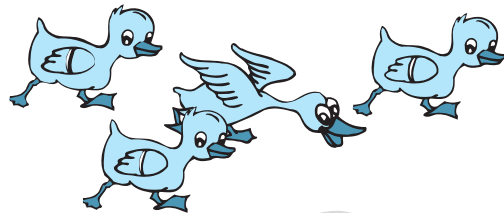

Bài giải

.....
.....
.....

XĂNG-TI-MÉT. ĐO ĐỘ DÀI



Thước có vạch chia thành từng xăng - ti - mét.
Xăng-ti-mét viết tắt là cm.

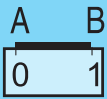

1cm
một xăng-ti-mét

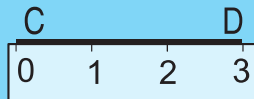

3cm
ba xăng-ti-mét

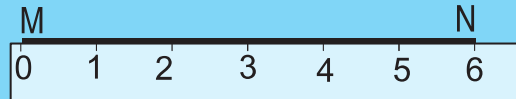

6cm
sáu xăng-ti-mét

1  Viết :

cm																			
----	--	--	--	--	--	--	--	--	--	--	--	--	--	--	--	--	--	--	--

2  Viết số thích hợp vào ô trống rồi đọc số đo :



cm

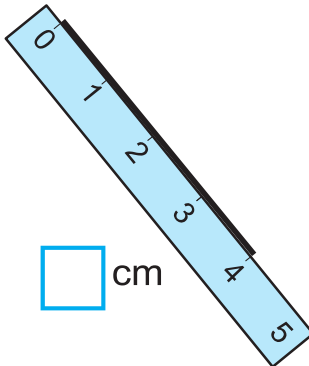

cm

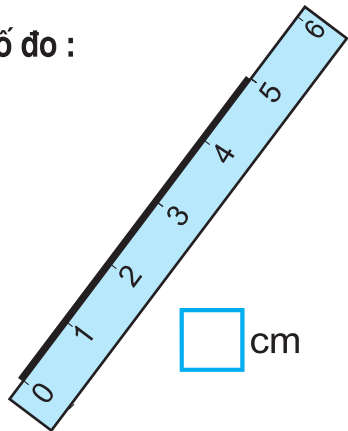

cm

3 Đặt thước đúng ghi đ, sai ghi s :

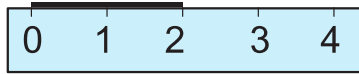
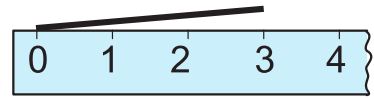

4 Đo độ dài mỗi đoạn thẳng rồi viết các số đo :



.....

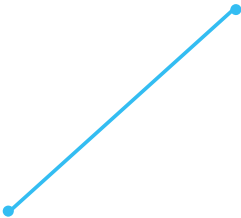

.....

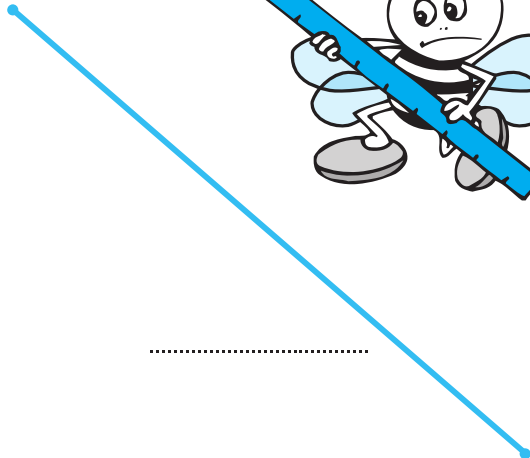

.....



.....

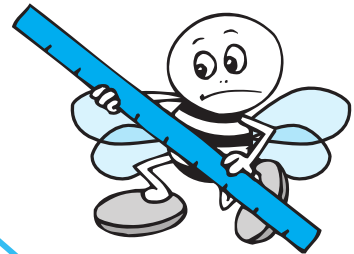

LUYỆN TẬP



- 1**  Trong vườn có 12 cây chuối, bố trồng thêm 3 cây chuối. Hỏi trong vườn có tất cả bao nhiêu cây chuối ?

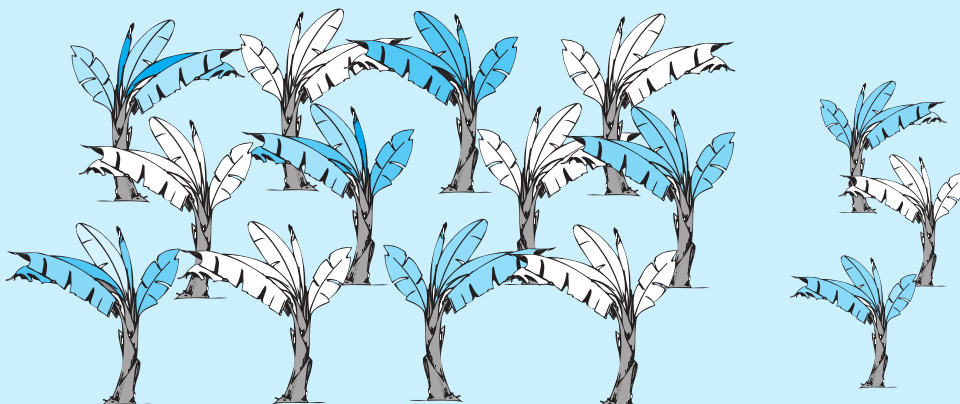

Tóm tắt

Có : ... cây
Thêm : ... cây
Có tất cả : ... cây ?

- 2**  Trên tường có 14 bức tranh, người ta treo thêm 2 bức tranh nữa. Hỏi trên tường có tất cả bao nhiêu bức tranh ?

Tóm tắt

Có : ... bức tranh
Thêm : ... bức tranh
Có tất cả : ... bức tranh ?

- 3**  Giải bài toán theo tóm tắt sau :

Có : 5 hình vuông
Có : 4 hình tròn
Có tất cả : ... hình vuông và hình tròn ?

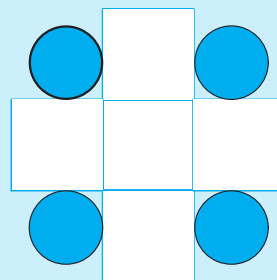



LUYỆN TẬP

1  An có 4 quả bóng xanh và 5 quả bóng đỏ. Hỏi An có tất cả mấy quả bóng ?

Tóm tắt

Có : ... bóng xanh

Có : ... bóng đỏ

Có tất cả : ... quả bóng ?

2  Tổ em có 5 bạn nam và 5 bạn nữ. Hỏi tổ em có tất cả mấy bạn ?

3  Giải bài toán theo tóm tắt sau :

Tóm tắt

Có : 2 gà trống

Có : 5 gà mái

Có tất cả : ... con gà ?

4  Tính (theo mẫu) :

a) $2\text{cm} + 3\text{cm} = 5\text{cm}$

$7\text{cm} + 1\text{cm} =$

$8\text{cm} + 2\text{cm} =$

$14\text{cm} + 5\text{cm} =$

b) $6\text{cm} - 2\text{cm} = 4\text{cm}$

$5\text{cm} - 3\text{cm} =$

$9\text{cm} - 4\text{cm} =$

$17\text{cm} - 7\text{cm} =$

VẼ ĐOẠN THẲNG CÓ ĐỘ DÀI CHO TRƯỚC

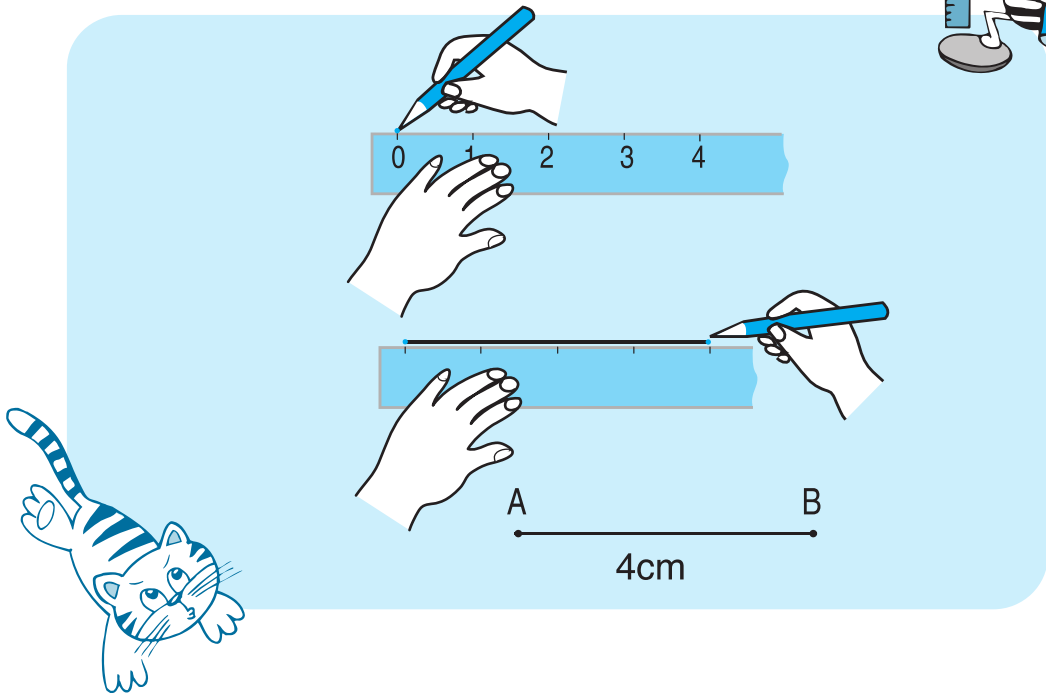

1  Vẽ đoạn thẳng có độ dài :

5cm ; 7cm ; 2cm ; 9cm.

2  Giải bài toán theo tóm tắt sau :

Tóm tắt

Đoạn thẳng AB : 5cm

Đoạn thẳng BC : 3cm

Cả hai đoạn thẳng : ... cm ?

3  Vẽ các đoạn thẳng AB, BC có độ dài nêu trong bài 2.



LUYỆN TẬP CHUNG

1  Điền số từ 1 đến 20 vào ô trống :

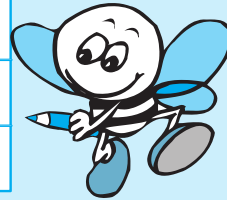



2  Điền số thích hợp vào ô trống :

$$11 \xrightarrow{+2} \square \xrightarrow{+3} \square$$

$$14 \xrightarrow{+1} \square \xrightarrow{+2} \square$$

$$15 \xrightarrow{+3} \square \xrightarrow{+1} \square$$

3  Một hộp có 12 bút xanh và 3 bút đỏ. Hỏi hộp đó có tất cả bao nhiêu cái bút ?

4  Điền số thích hợp vào ô trống (theo mẫu) :

13	1	2	3	4	5	6
	14					

12	4	1	7	5	2	0
	16					

LUYỆN TẬP CHUNG



1  Tính :

a) $12 + 3 =$ $15 + 4 =$ $8 + 2 =$ $14 + 3 =$

$15 - 3 =$ $19 - 4 =$ $10 - 2 =$ $17 - 3 =$

b) $11 + 4 + 2 =$ $19 - 5 - 4 =$ $14 + 2 - 5 =$

2  a) Khoanh vào số lớn nhất : 14 , 18 , 11 , 15

b) Khoanh vào số bé nhất : 17 , 13 , 19 , 10.

3  Vẽ đoạn thẳng có độ dài 4cm.

4  Đoạn thẳng AB dài 3cm và đoạn thẳng BC dài 6cm. Hỏi đoạn thẳng AC dài mấy xăng-ti-mét ?

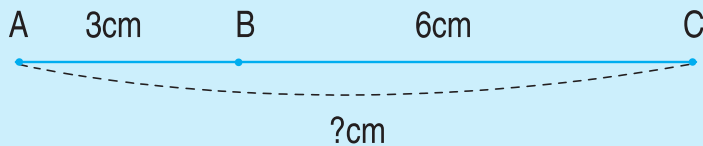

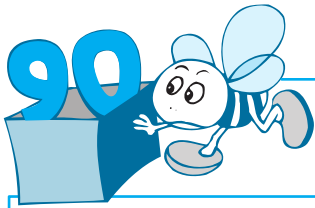

CÁC SỐ TRÒN CHỤC

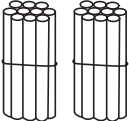
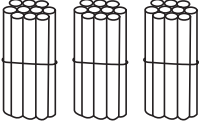
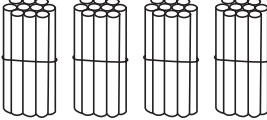
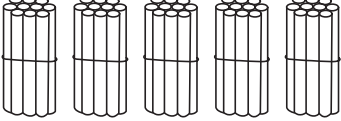
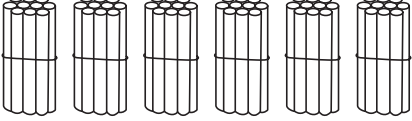
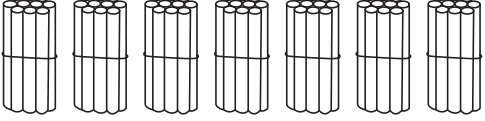
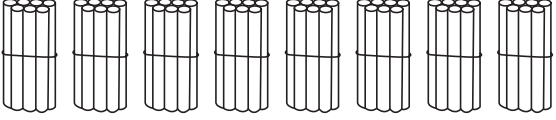
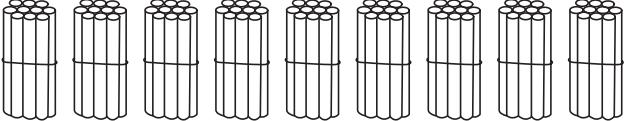
	SỐ CHỤC	VIẾT SỐ	ĐỌC SỐ
	1 chục	10	mười
	2 chục	20	hai mươi
	3 chục	30	ba mươi
	4 chục	40	bốn mươi
	5 chục	50	năm mươi
	... chục	60	sáu mươi
	... chục	70	bảy mươi
	... chục	...	tám mươi
	... chục

1 Viết (theo mẫu) :

a)

VIẾT SỐ	ĐỌC SỐ
20	hai mươi
10	
90	
70	

ĐỌC SỐ	VIẾT SỐ
Sáu mươi	60
Tám mươi	
Năm mươi	
Ba mươi	

b) Ba chục : 30
 Tám chục : ...
 Một chục : ...

Bốn chục : ...
 Sáu chục : ...
 Năm chục : ...

c) 20 : hai chục
 70 : ... chục
 90 : ... chục

50 :
 80 :
 30 :

2 Số tròn chục ?

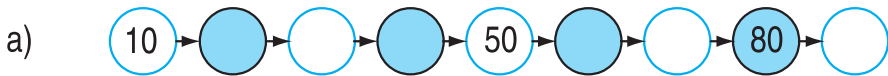

3

20 ... 10
 30 ... 40
 50 ... 70

40 ... 80
 80 ... 40
 40 ... 40

90 ... 60
 60 ... 90
 90 ... 90

CỘNG CÁC SỐ TRÒN CHỤC

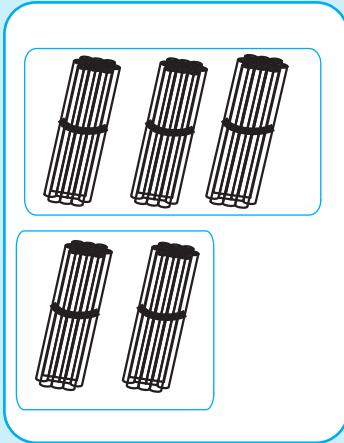

CHỤC	ĐƠN VỊ
3	0
+ 2	0
5	0

$$\begin{array}{r}
 30 \\
 + 20 \\
 \hline
 50
 \end{array}$$

- 0 cộng 0 bằng 0, viết 0
- 3 cộng 2 bằng 5, viết 5

$30 + 20 = \dots$

1 Tính :

40	50	30	10	20	60
+ 30	+ 40	+ 30	+ 70	+ 50	+ 20
<u> </u>	<u> </u>	<u> </u>	<u> </u>	<u> </u>	<u> </u>

2 Tính nhẩm :

$20 + 30 = ?$

Nhẩm : 2 chục + 3 chục = 5 chục

Vậy : $20 + 30 = 50$

$50 + 10 =$	$40 + 30 =$	$50 + 40 =$
$20 + 20 =$	$20 + 60 =$	$40 + 50 =$
$30 + 50 =$	$70 + 20 =$	$20 + 70 =$

3 Thùng thứ nhất đựng 20 gói bánh, thùng thứ hai đựng 30 gói bánh. Hỏi cả hai thùng đựng bao nhiêu gói bánh ?



LUYỆN TẬP

1  Đặt tính rồi tính :

$40 + 20$

$10 + 70$

$60 + 20$

$30 + 30$

$50 + 40$

$30 + 40$

2  Tính nhẩm :

a) $30 + 20 =$

$40 + 50 =$

$10 + 60 =$

$20 + 30 =$

$50 + 40 =$

$60 + 10 =$

b) $30\text{cm} + 10\text{cm} =$

$50\text{cm} + 20\text{cm} =$

$40\text{cm} + 40\text{cm} =$

$20\text{cm} + 30\text{cm} =$

3  Lan hái được 20 bông hoa, Mai hái được 10 bông hoa. Hỏi cả hai bạn hái được bao nhiêu bông hoa ?

4  Nói (theo mẫu) :

20 + 20

40 + 40

10 + 60

60 + 20

80

70

40

50

30 + 20

40 + 30

30 + 10

10 + 40



TRỪ CÁC SỐ TRÒN CHỤC

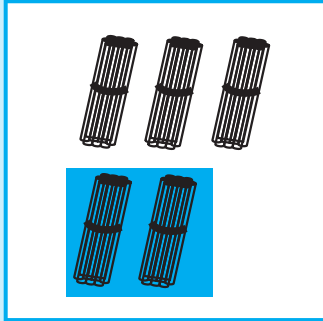

CHỤC	ĐƠN VỊ
5	0
- 2	0
3	0

$$\begin{array}{r}
 50 \\
 - 20 \\
 \hline
 30
 \end{array}$$

• 0 trừ 0 bằng 0, viết 0
• 5 trừ 2 bằng 3, viết 3

$50 - 20 = \dots$



Tính :

$$\begin{array}{r}
 40 \\
 - 20 \\
 \hline
 \end{array}$$

$$\begin{array}{r}
 80 \\
 - 50 \\
 \hline
 \end{array}$$

$$\begin{array}{r}
 90 \\
 - 10 \\
 \hline
 \end{array}$$

$$\begin{array}{r}
 70 \\
 - 30 \\
 \hline
 \end{array}$$

$$\begin{array}{r}
 90 \\
 - 40 \\
 \hline
 \end{array}$$

$$\begin{array}{r}
 60 \\
 - 60 \\
 \hline
 \end{array}$$



Tính nhẩm :

$50 - 30 = ?$

Nhẩm : 5 chục - 3 chục = 2 chục

Vậy : $50 - 30 = 20$

$40 - 30 =$

$80 - 40 =$

$70 - 20 =$

$90 - 60 =$

$90 - 10 =$

$50 - 50 =$



An có 30 cái kẹo, chị cho An thêm 10 cái nữa. Hỏi An có tất cả bao nhiêu cái kẹo ?



?

$50 - 10 \dots 20$

$40 - 10 \dots 40$

$30 \dots 50 - 20$



LUYỆN TẬP

1  Đặt tính rồi tính :

$70 - 50$

$60 - 30$

$90 - 50$

$80 - 40$

$40 - 10$

$90 - 40$

2  Số ?

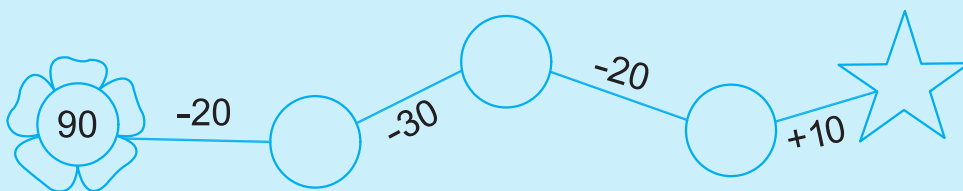



3  Đúng ghi đ, sai ghi s :

a) $60\text{cm} - 10\text{cm} = 50$

b) $60\text{cm} - 10\text{cm} = 50\text{cm}$

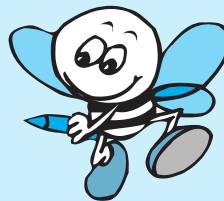
c) $60\text{cm} - 10\text{cm} = 40\text{cm}$



4  Nhà Lan có 20 cái bát, mẹ mua thêm 1 chục cái nữa. Hỏi nhà Lan có tất cả bao nhiêu cái bát ?

5  \pm ?

$50 \dots 10 = 40$

$30 \dots 20 = 50$

$40 \dots 20 = 20$

ĐIỂM Ở TRONG, ĐIỂM Ở NGOÀI MỘT HÌNH

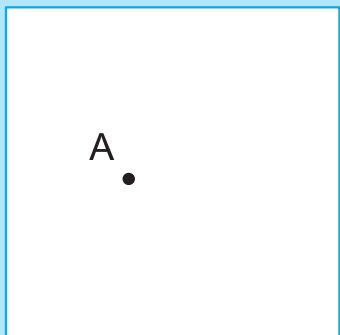
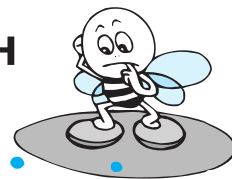

Điểm A ở trong hình vuông
Điểm N ở ngoài hình vuông

N

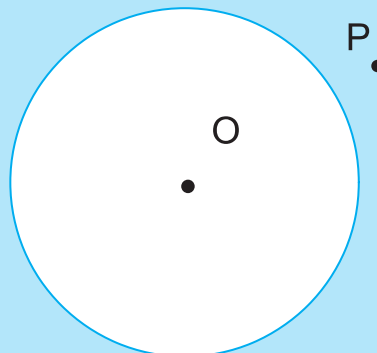

Điểm O ở trong hình tròn
Điểm P ở ngoài hình tròn

1  Đúng ghi đ, sai ghi s :

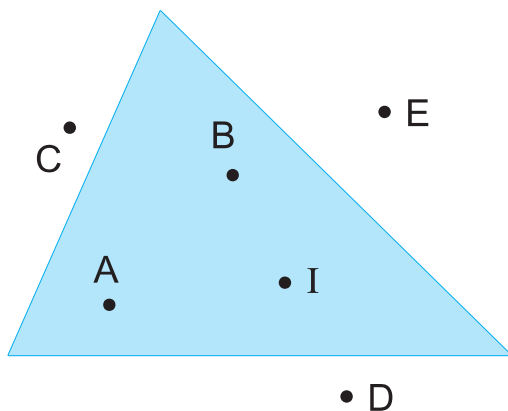

Điểm A ở trong hình tam giác

Điểm B ở ngoài hình tam giác

Điểm E ở ngoài hình tam giác

Điểm C ở ngoài hình tam giác

Điểm I ở ngoài hình tam giác

Điểm D ở ngoài hình tam giác



- 2**  a) Vẽ 2 điểm ở trong hình vuông.
Vẽ 4 điểm ở ngoài hình vuông.

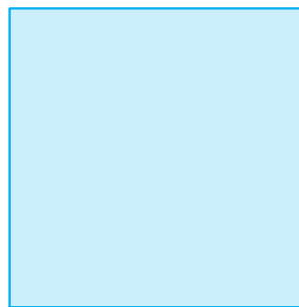

- b) Vẽ 3 điểm ở trong hình tròn.
Vẽ 2 điểm ở ngoài hình tròn.

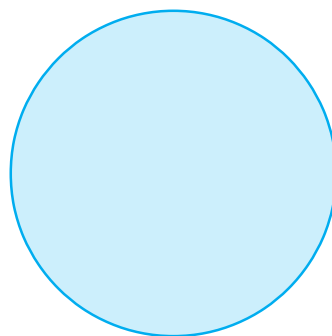

3  Tính :

$$20 + 10 + 10 =$$
$$30 + 10 + 20 =$$
$$30 + 20 + 10 =$$

$$60 - 10 - 20 =$$

$$60 - 20 - 10 =$$

$$70 + 10 - 20 =$$

- 4**  Hoa có 10 nhãn vở, mẹ mua cho Hoa thêm 20 nhãn vở nữa. Hỏi Hoa có tất cả bao nhiêu nhãn vở ?

LUYỆN TẬP CHUNG



- 1**  **Viết (theo mẫu) :** Số 10 gồm 1 chục và 0 đơn vị
 Số 18 gồm ... chục và ... đơn vị
 Số 40 gồm ... chục và ... đơn vị
 Số 70 gồm ... chục và ... đơn vị

- 2**  a) Viết các số theo thứ tự từ **bé đến lớn** :

--	--	--	--

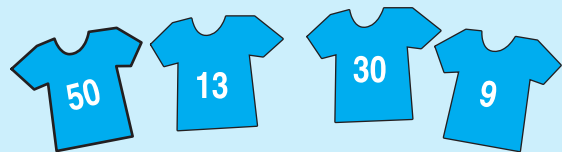

- b) Viết các số theo thứ tự từ **lớn đến bé** :

--	--	--	--

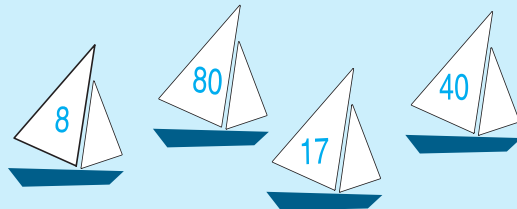

- 3**  a) Đặt tính rồi tính :
- | | | |
|-----------|-----------|-----------|
| $70 + 20$ | $80 - 30$ | $10 + 60$ |
| $20 + 70$ | $80 - 50$ | $90 - 40$ |

- b) Tính nhẩm :
- | | |
|-------------|-------------------------------|
| $50 + 20 =$ | $60\text{cm} + 10\text{cm} =$ |
| $70 - 50 =$ | $30\text{cm} + 20\text{cm} =$ |
| $70 - 20 =$ | $40\text{cm} - 20\text{cm} =$ |

- 4**  Lớp 1A vẽ được 20 bức tranh, lớp 1B vẽ được 30 bức tranh. Hỏi cả hai lớp vẽ được bao nhiêu bức tranh ?

- 5**  Vẽ 3 điểm ở trong hình tam giác.
 Vẽ 2 điểm ở ngoài hình tam giác.

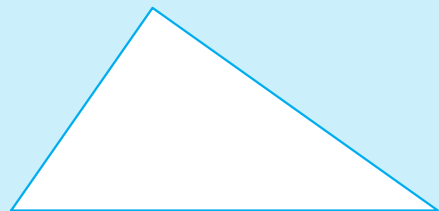



CÁC SỐ CÓ HAI CHỮ SỐ

	CHỤC	ĐƠN VỊ	VIẾT SỐ	ĐỌC SỐ
	2	3	23	hai mươi ba
	3	6	36	ba mươi sáu
	4	2	42	bốn mươi hai



a) Viết số :

Hai mươi, hai mươi mốt, hai mươi hai, hai mươi ba, hai mươi tư,
hai mươi lăm, hai mươi sáu, hai mươi bảy, hai mươi tám, hai mươi chín.

b) Viết số vào dưới mỗi vạch của tia số rồi đọc các số đó :



Viết số :

Ba mươi, ba mươi mốt, ba mươi hai, ba mươi ba, ba mươi tư, ba mươi lăm, ba mươi sáu, ba mươi bảy, ba mươi tám, ba mươi chín.

Viết số :

Bốn mươi, bốn mươi mốt, bốn mươi hai, bốn mươi ba, bốn mươi tư, bốn mươi lăm, bốn mươi sáu, bốn mươi bảy, bốn mươi tám, bốn mươi chín, năm mươi.

Viết số thích hợp vào ô trống rồi đọc các số đó :

24		26				30						36
----	--	----	--	--	--	----	--	--	--	--	--	----

35			38				42				46
----	--	--	----	--	--	--	----	--	--	--	----

	40					45					50
--	----	--	--	--	--	----	--	--	--	--	----



CÁC SỐ CÓ HAI CHỮ SỐ (tiếp theo)

	CHỤC	ĐƠN VỊ	VIẾT SỐ	ĐỌC SỐ
	54	năm mươi tư
	61	sáu mươi một
	68	sáu mươi tám



1 Viết số :

Năm mươi, năm mươi một, năm mươi hai, năm mươi ba, năm mươi tư, năm mươi lăm, năm mươi sáu, năm mươi bảy, năm mươi tám, năm mươi chín.

2 Viết số :

Sáu mươi, sáu mươi một, sáu mươi hai, sáu mươi ba, sáu mươi tư, sáu mươi lăm, sáu mươi sáu, sáu mươi bảy, sáu mươi tám, sáu mươi chín, bảy mươi.

3 Viết số thích hợp vào ô trống :

30			33					38	
	41				45				
		52					57		
60									69

4 Đúng ghi đ, sai ghi s :

a) Ba mươi sáu viết là 306



Ba mươi sáu viết là 36



b) 54 gồm 5 chục và 4 đơn vị



54 gồm 5 và 4

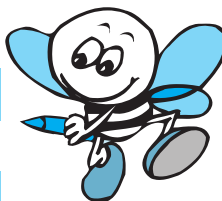

CÁC SỐ CÓ HAI CHỮ SỐ (tiếp theo)



	CHỤC	ĐƠN VỊ	VIẾT SỐ	ĐỌC SỐ
	bảy mươi hai
	tám mươi tư

1 Viết số :

Bảy mươi, bảy mươi mốt, bảy mươi hai, bảy mươi ba, bảy mươi tư, bảy mươi lăm, bảy mươi sáu, bảy mươi bảy, bảy mươi tám, bảy mươi chín, tám mươi.

2  **Viết số thích hợp vào ô trống rồi đọc các số đó :**

a)

80			83							90
----	--	--	----	--	--	--	--	--	--	----

b)

	90							97		99
--	----	--	--	--	--	--	--	----	--	----

3  **Viết (theo mẫu) :**

- a) Số 76 gồm 7 chục và 6 đơn vị
- b) Số 95 gồm ... chục và ... đơn vị
- c) Số 83 gồm ... chục và ... đơn vị
- d) Số 90 gồm ... chục và ... đơn vị

4  Trong hình vẽ có bao nhiêu cái bát ?

Trong số đó có mấy chục và mấy đơn vị ?

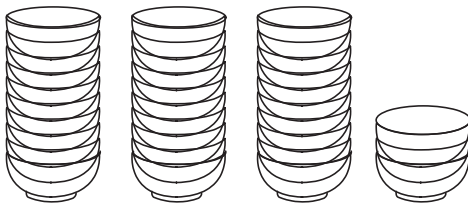



SO SÁNH CÁC SỐ CÓ HAI CHỮ SỐ

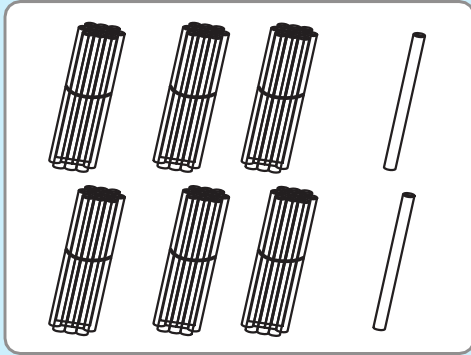

$$62 < 65$$

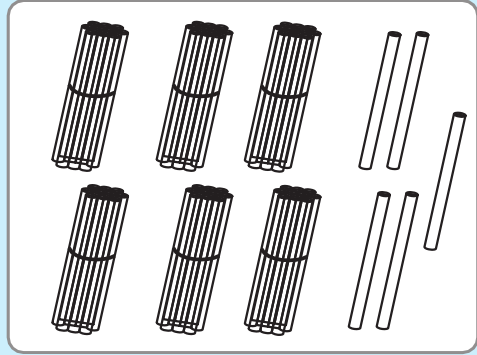

$$62 < 65$$

$$65 > 62$$

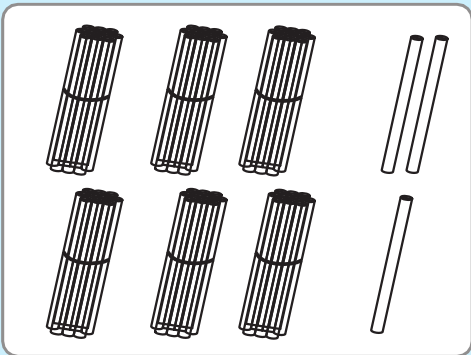

$$63 > 58$$

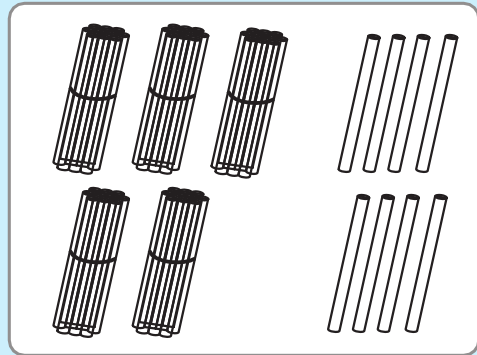

$$63 > 58$$

$$58 < 63$$

1 



?

34 ... 38

36 ... 30

37 ... 37

25 ... 30

55 ... 57

55 ... 55

55 ... 51

85 ... 95

90 ... 90

97 ... 92

92 ... 97

48 ... 42

2  Khoanh vào số *lớn nhất* :

a) 72 , 68 , 80

b) 91 , 87 , 69

c) 97 , 94 , 92

d) 45 , 40 , 38.

3  Khoanh vào số *bé nhất* :

a) 38 , 48 , 18

b) 76 , 78 , 75

c) 60 , 79 , 61

d) 79 , 60 , 81.

4  Viết các số 72, 38, 64 :

a) Theo thứ tự từ bé đến lớn :

b) Theo thứ tự từ lớn đến bé :



LUYỆN TẬP

1 Viết số :

- a) Ba mươi, mười ba, mười hai, hai mươi.
- b) Bảy mươi bảy, bốn mươi tư, chín mươi sáu, sáu mươi chín.
- c) Tám mươi mốt, mười, chín mươi chín, bốn mươi tám.

2 Viết (theo mẫu) :

Mẫu : Số liền sau của 80 là 81

- a) Số liền sau của 23 là ... ; Số liền sau của 70 là ...
- b) Số liền sau của 84 là ... ; Số liền sau của 98 là ...
- c) Số liền sau của 54 là ... ; Số liền sau của 69 là ...
- d) Số liền sau của 39 là ... ; Số liền sau của 40 là ...

3



- | | | |
|--------------|--------------|--------------|
| a) 34 ... 50 | b) 47 ... 45 | c) 55 ... 66 |
| 78 ... 69 | 81 ... 82 | 44 ... 33 |
| 72 ... 81 | 95 ... 90 | 77 ... 99 |
| 62 ... 62 | 61 ... 63 | 88 ... 22 |

4 Viết (theo mẫu) :

- a) 87 gồm 8 chục và 7 đơn vị ; ta viết : $87 = 80 + 7$
- b) 59 gồm ... chục và ... đơn vị ; ta viết : $59 = \dots + \dots$
- c) 20 gồm ... chục và ... đơn vị ; ta viết : $20 = \dots + \dots$
- d) 99 gồm ... chục và ... đơn vị ; ta viết : $99 = \dots + \dots$

BẢNG CÁC SỐ TỪ 1 ĐẾN 100

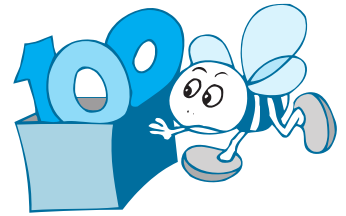

Số liền sau của 97 là ... ;

Số liền sau của 98 là ...

Số liền sau của 99 là ... ;

100 đọc là **một trăm**



Viết số còn thiếu vào ô trống trong bảng các số từ 1 đến 100 :

1	2	3	4	5	6	7	8	9	10
11	12		14		16		18		20
21		23		25		27		29	
31	32		34		36		38		
41		43		45		47		49	
51	52		54		56		58		60
61		63		65		67		69	
71			74		76		78		80
81		83		85		87		89	
91	92		94		96		98		



Trong bảng các số từ 1 đến 100 :

a) Các số có một chữ số là :

b) Các số tròn chục là :

c) Số bé nhất có hai chữ số là :

d) Số lớn nhất có hai chữ số là :

đ) Các số có hai chữ số giống nhau là : 11, 22,



LUYỆN TẬP

1 Viết số :

Ba mươi ba, chín mươi, chín mươi chín, năm mươi tám, tám mươi lăm, hai mươi mốt, bảy mươi mốt, sáu mươi sáu, một trăm.

2 Viết số :

- a) Số liền trước của 62 là ... ; Số liền trước của 61 là ...
 Số liền trước của 80 là ... ; Số liền trước của 79 là ...
 Số liền trước của 99 là ... ; Số liền trước của 100 là ...
- b) Số liền sau của 20 là ... ; Số liền sau của 38 là ...
 Số liền sau của 75 là ... ; Số liền sau của 99 là ...

c)

Số liền trước	Số đã biết	Số liền sau
44	45	46
	69	
	99	

3 Viết các số :

Từ 50 đến 60 :

Từ 85 đến 100 :

4 Dùng thước và bút nối các điểm để có hai hình vuông :

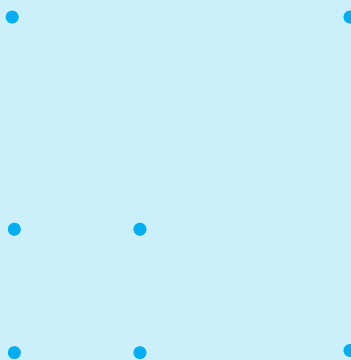

LUYỆN TẬP CHUNG



1  **Viết các số :**

a) Từ 15 đến 25 :

.....

b) Từ 69 đến 79 :

.....

2  **Đọc mỗi số sau :** 35, 41, 64, 85, 69, 70.

3 



?

a) 72 ... 76

b) 85 ... 65

c) 15 ... 10 + 4

85 ... 81

42 ... 76

16 ... 10 + 6

45 ... 47

33 ... 66

18 ... 15 + 3

4  Có 10 cây cam và 8 cây chanh. Hỏi có tất cả bao nhiêu cây ?

5  Viết số lớn nhất có hai chữ số.



GIẢI TOÁN CÓ LỜI VĂN (tiếp theo)

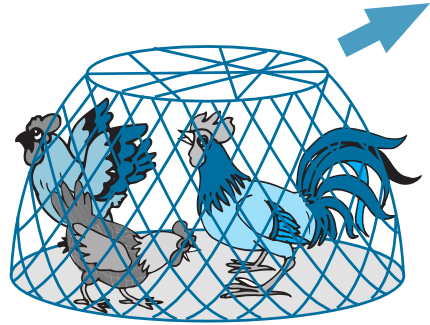
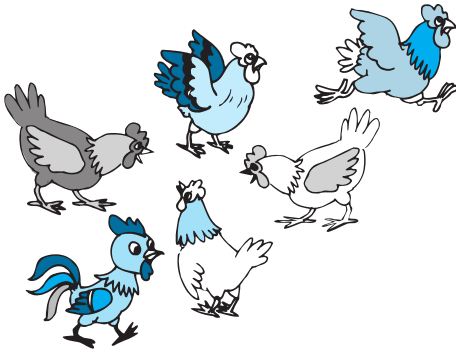

Bài toán : Nhà An có 9 con gà, mẹ đem bán 3 con gà. Hỏi nhà An còn lại mấy con gà ?

Tóm tắt

Có : 9 con gà
Bán : 3 con gà
Còn lại : ... con gà ?

Bài giải

Số gà còn lại là :
 $9 - 3 = 6$ (con)
Đáp số : 6 con gà.

1  Có 8 con chim đậu trên cây, sau đó có 2 con bay đi. Hỏi trên cây còn lại bao nhiêu con chim ?

Tóm tắt

Có : ... con chim
Bay đi : ... con chim
Còn lại : ... con chim ?

Bài giải

Số chim còn lại là :
..... = ... (con)

Đáp số : ... con chim.

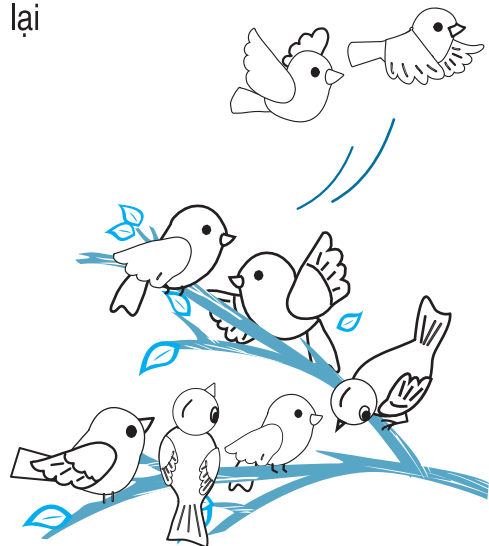



LUYỆN TẬP

- 1**  Cửa hàng có 15 bút bê, đã bán đi 2 bút bê. Hỏi cửa hàng còn lại bao nhiêu bút bê ?

Tóm tắt Có : ... bút bê
Đã bán : ... bút bê
Còn lại : ... bút bê ?

- 2**  Trên sân bay có 12 máy bay, sau đó có 2 máy bay bay đi. Hỏi trên sân bay còn lại bao nhiêu máy bay ?

Tóm tắt Có : ... máy bay
Bay đi : ... máy bay
Còn lại : ... máy bay ?

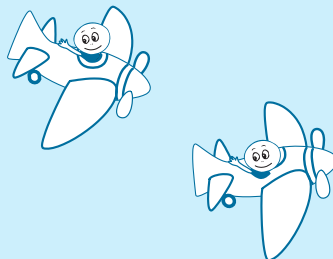

- 3**  Điền số thích hợp vào ô trống :

$$17 \xrightarrow{-2} \square \xrightarrow{-3} \square$$

$$18 \xrightarrow{-4} \square \xrightarrow{+1} \square$$

$$14 \xrightarrow{+2} \square \xrightarrow{-5} \square$$

- 4**  Giải bài toán theo tóm tắt sau :

Có : 8 hình tam giác
Tô màu : 4 hình tam giác
Không tô màu : ... hình tam giác ?

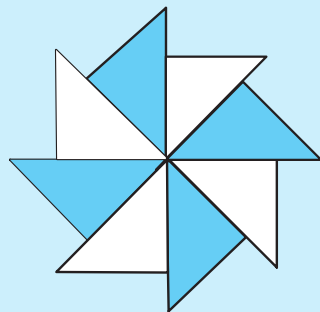

LUYỆN TẬP



- 1** Lan gấp được 14 cái thuyền, Lan cho bạn 4 cái thuyền. Hỏi Lan còn bao nhiêu cái thuyền ?

Tóm tắt

Có : ... cái thuyền

Cho bạn : ... cái thuyền

Còn lại : ... cái thuyền ?

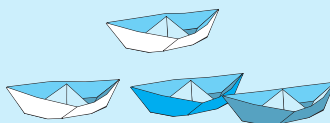

- 2** Tổ em có 9 bạn, trong đó có 5 bạn nữ. Hỏi tổ em có mấy bạn nam ?

- 3** Một sợi dây dài 13cm, đã cắt đi 2cm. Hỏi sợi dây còn lại dài bao nhiêu xăng-ti-mét ?



- 4** Giải bài toán theo tóm tắt sau :

Có : 15 hình tròn

Tô màu : 4 hình tròn

Không tô màu : ... hình tròn ?

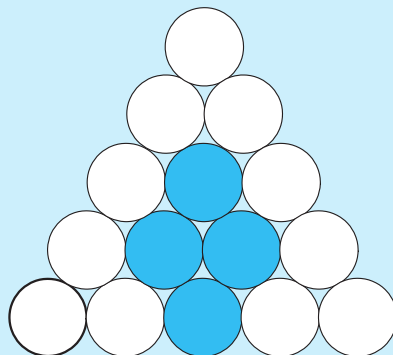



LUYỆN TẬP CHUNG

1  Nhìn tranh vẽ, viết tiếp vào chỗ chấm để có bài toán, rồi giải bài toán đó :

a) **Bài toán :**

Trong bến có . . . ô tô,
có thêm . . . ô tô vào bến.

Hỏi.....
..... ?

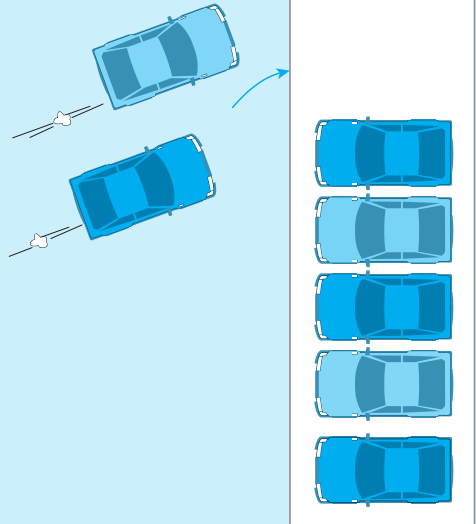

b) **Bài toán :**

Lúc đầu trên cành có 6 con chim,
có . . . con chim bay đi.

Hỏi
..... ?

2  Nhìn tranh vẽ, nêu tóm tắt bài toán, rồi giải bài toán đó :

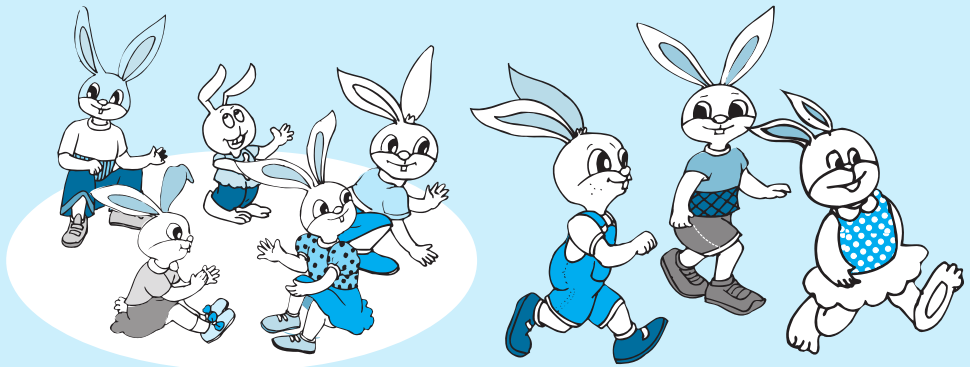

4. PHÉP CỘNG, PHÉP TRỪ TRONG PHẠM VI 100. ĐO THỜI GIAN



PHÉP CỘNG TRONG PHẠM VI 100 (cộng không nhớ)

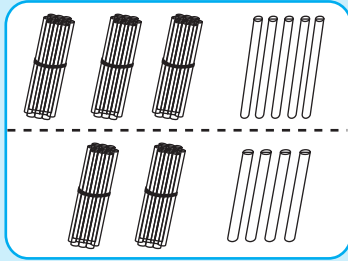

$$35 + 24 = \dots$$

CHỤC	ĐƠN VỊ
3	5
+	2
5	9

$$\begin{array}{r} 35 \\ + 24 \\ \hline 59 \end{array}$$

- 5 cộng 4 bằng 9, viết 9
- 3 cộng 2 bằng 5, viết 5

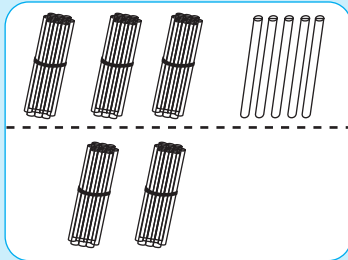

$$35 + 20 = \dots$$

CHỤC	ĐƠN VỊ
3	5
+	2
5	5

$$\begin{array}{r} 35 \\ + 20 \\ \hline 55 \end{array}$$

- 5 cộng 0 bằng 5, viết 5
- 3 cộng 2 bằng 5, viết 5

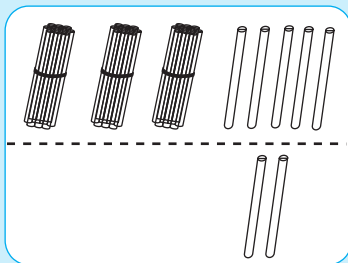

$$35 + 2 = \dots$$

CHỤC	ĐƠN VỊ
3	5
+	2
3	7

$$\begin{array}{r} 35 \\ + 2 \\ \hline 37 \end{array}$$

- 5 cộng 2 bằng 7, viết 7
- Hạ 3, viết 3



Tính :

$$\begin{array}{r} 52 \\ + 36 \\ \hline \end{array}$$

$$\begin{array}{r} 82 \\ + 14 \\ \hline \end{array}$$

$$\begin{array}{r} 43 \\ + 15 \\ \hline \end{array}$$

$$\begin{array}{r} 76 \\ + 10 \\ \hline \end{array}$$

$$\begin{array}{r} 63 \\ + 5 \\ \hline \end{array}$$

$$\begin{array}{r} 9 \\ + 10 \\ \hline \end{array}$$

2  Đặt tính rồi tính :

$35 + 12$

$60 + 38$

$6 + 43$

$41 + 34$

$22 + 40$

$54 + 2$

3  Lớp 1A trồng được 35 cây, lớp 2A trồng được 50 cây. Hỏi hai lớp trồng được tất cả bao nhiêu cây ?

4  Đo độ dài của mỗi đoạn thẳng rồi viết số đo :

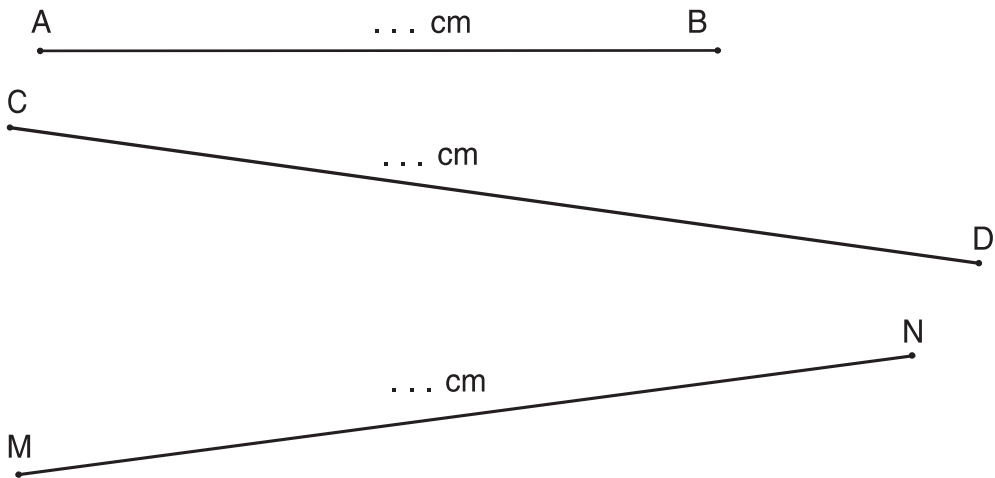



LUYỆN TẬP

1  Đặt tính rồi tính :

$47 + 22$

$40 + 20$

$12 + 4$

$51 + 35$

$80 + 9$

$8 + 31$

2  Tính nhẩm :

$30 + 6 =$

$60 + 9 =$

$52 + 6 =$

$82 + 3 =$

$40 + 5 =$

$70 + 2 =$

$6 + 52 =$

$3 + 82 =$

3  Lớp em có 21 bạn gái và 14 bạn trai. Hỏi lớp em có tất cả bao nhiêu bạn ?

4  Vẽ đoạn thẳng có độ dài 8cm.



LUYỆN TẬP



1  Tính :

+	53
+	14
<hr/>	

+	35
+	22
<hr/>	

+	55
+	23
<hr/>	

+	44
+	33
<hr/>	

+	17
+	71
<hr/>	

+	42
+	53
<hr/>	

2  Tính :

20cm + 10cm =	30cm + 40cm =
14cm + 5cm =	25cm + 4cm =
32cm + 12cm =	43cm + 15cm =

3  Nói (theo mẫu) :

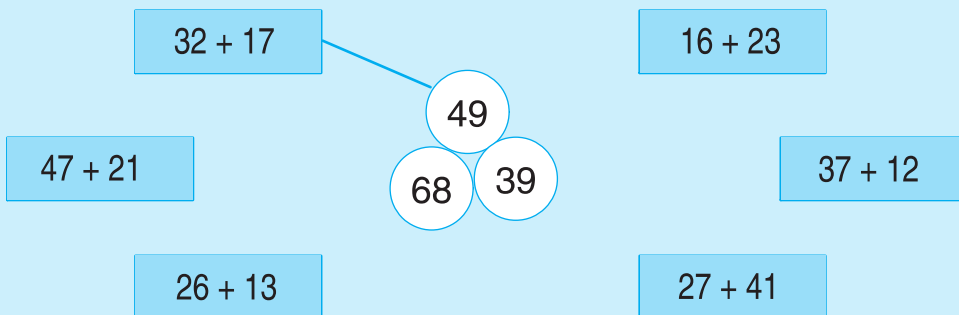

4  Lúc đầu con sên bò được 15cm, sau đó bò tiếp được 14cm.
Hỏi con sên bò được tất cả bao nhiêu xăng-ti-mét ?

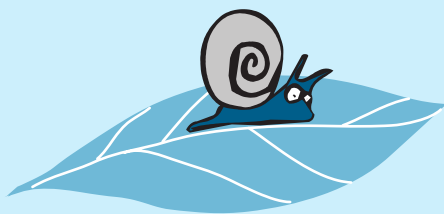

PHÉP TRỪ TRONG PHẠM VI 100 (trừ không nhớ)

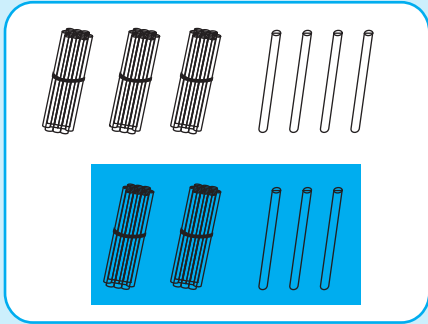

CHỤC	ĐƠN VỊ	
5	7	57
- 2	3	- 23
3	4	34

- 7 trừ 3 bằng 4, viết 4
- 5 trừ 2 bằng 3, viết 3

$$57 - 23 = \dots$$



a) Tính :

85
- 64
—

49
- 25
—

98
- 72
—

35
- 15
—

59
- 53
—

b) Đặt tính rồi tính :

67 - 22

56 - 16

94 - 92

42 - 42

99 - 66



Đúng ghi đ, sai ghi s :

a)

87
- 35
—
52

68
- 21
—
46

95
- 24
—
61

43
- 12
—
55

b)

57
- 23
—
34

74
- 11
—
63

88
- 80
—
08

47
- 47
—
00



Quyển sách của Lan gồm 64 trang, Lan đã đọc được 24 trang. Hỏi Lan còn phải đọc bao nhiêu trang nữa thì hết quyển sách ?

PHÉP TRỪ TRONG PHẠM VI 100 (trừ không nhớ)

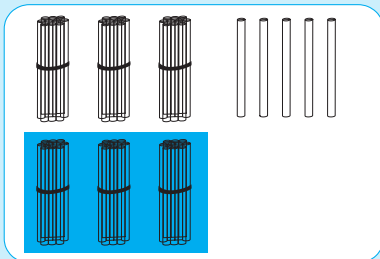

$$65 - 30 = \dots$$

CHỤC	ĐƠN VỊ
6	5
<u> </u> - 3	<u> </u> 0
3	5

$$\begin{array}{r} 65 \\ - 30 \\ \hline 35 \end{array}$$

- 5 trừ 0 bằng 5, viết 5
- 6 trừ 3 bằng 3, viết 3

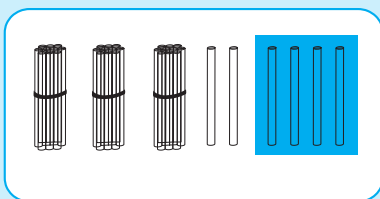

$$36 - 4 = \dots$$

CHỤC	ĐƠN VỊ
3	6
<u> </u> -	<u> </u> 4
3	2

$$\begin{array}{r} 36 \\ - 4 \\ \hline 32 \end{array}$$

- 6 trừ 4 bằng 2, viết 2
- Hạ 3, viết 3



Tính :

a) $\begin{array}{r} 82 \\ - 50 \\ \hline \end{array}$ $\begin{array}{r} 75 \\ - 40 \\ \hline \end{array}$ $\begin{array}{r} 48 \\ - 20 \\ \hline \end{array}$ $\begin{array}{r} 69 \\ - 50 \\ \hline \end{array}$ $\begin{array}{r} 98 \\ - 30 \\ \hline \end{array}$ $\begin{array}{r} 55 \\ - 55 \\ \hline \end{array}$

b) $\begin{array}{r} 68 \\ - 4 \\ \hline \end{array}$ $\begin{array}{r} 37 \\ - 2 \\ \hline \end{array}$ $\begin{array}{r} 88 \\ - 7 \\ \hline \end{array}$ $\begin{array}{r} 33 \\ - 3 \\ \hline \end{array}$ $\begin{array}{r} 79 \\ - 0 \\ \hline \end{array}$ $\begin{array}{r} 54 \\ - 4 \\ \hline \end{array}$



Đúng ghi đ, sai ghi s :

a) $\begin{array}{r} 57 \\ - 5 \\ \hline 50 \end{array}$ b) $\begin{array}{r} 57 \\ - 5 \\ \hline 52 \end{array}$ c) $\begin{array}{r} 57 \\ - 5 \\ \hline 07 \end{array}$ d) $\begin{array}{r} 57 \\ - 5 \\ \hline 52 \end{array}$



Tính nhẩm :

a) $66 - 60 =$ $98 - 90 =$ $72 - 70 =$
 $78 - 50 =$ $59 - 30 =$ $43 - 20 =$

b) $58 - 4 =$ $67 - 7 =$ $99 - 1 =$
 $58 - 8 =$ $67 - 5 =$ $99 - 9 =$



LUYỆN TẬP

1  Đặt tính rồi tính :

$45 - 23$

$57 - 31$

$72 - 60$

$70 - 40$

$66 - 25$

2  Tính nhẩm :

$65 - 5 =$

$65 - 60 =$

$65 - 65 =$

$70 - 30 =$

$94 - 3 =$

$33 - 30 =$

$21 - 1 =$

$21 - 20 =$

$32 - 10 =$

3 



$35 - 5$

$35 - 4$

$43 + 3$

$43 - 3$

$30 - 20$

$40 - 30$

$31 + 42$

$41 + 32$

4  Lớp 1B có 35 bạn, trong đó có 20 bạn nữ. Hỏi lớp 1B có bao nhiêu bạn nam ?

5  Nói (theo mẫu) :

$76 - 5$

$40 + 14$

$68 - 14$

54

71

$11 + 21$

$42 - 12$

32

$60 + 11$

CÁC NGÀY TRONG TUẦN LỄ



Một tuần lễ có 7 ngày là :

Chủ nhật, thứ hai, thứ ba, thứ tư, thứ năm, thứ sáu, thứ bảy.



Trong mỗi tuần lễ :

a) Em đi học vào các ngày : thứ hai,

.....

b) Em được nghỉ các ngày :



Đọc tờ lịch của ngày hôm nay rồi viết lần lượt tên ngày trong tuần, ngày trong tháng, tên tháng :

a) Hôm nay là ngày tháng.....

b) Ngày mai là ngày tháng.....



Đọc thời khoá biểu của lớp em.

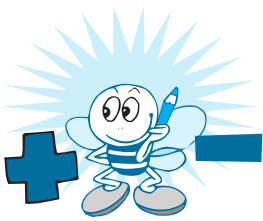

CỘNG, TRỪ (không nhớ) TRONG PHẠM VI 100

1 Tính nhẩm :

$80 + 10 =$

$30 + 40 =$

$80 + 5 =$

$90 - 80 =$

$70 - 30 =$

$85 - 5 =$

$90 - 10 =$

$70 - 40 =$

$85 - 80 =$

2 Đặt tính rồi tính :

$36 + 12$

$65 + 22$

$48 - 36$

$87 - 65$

$48 - 12$

$87 - 22$

3  Hà có 35 que tính, Lan có 43 que tính. Hỏi hai bạn có tất cả bao nhiêu que tính ?

Tóm tắt

Hà có : 35 que tính }
Lan có : 43 que tính } ? que tính

4  Hà và Lan hái được 68 bông hoa, riêng Hà hái được 34 bông hoa. Hỏi Lan hái được bao nhiêu bông hoa ?

Tóm tắt

Tất cả có : 68 bông hoa
Hà có : 34 bông hoa
Lan có : ... bông hoa ?

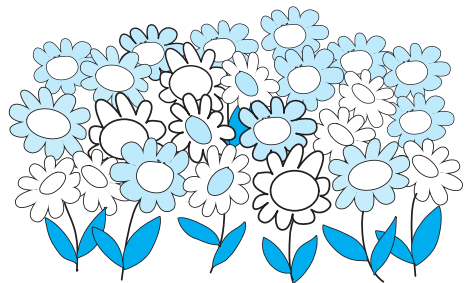

LUYỆN TẬP



1 Đặt tính rồi tính :

$$34 + 42$$

$$76 - 42$$

$$52 + 47$$

$$42 + 34$$

$$76 - 34$$

$$47 + 52$$

2 Viết phép tính thích hợp :

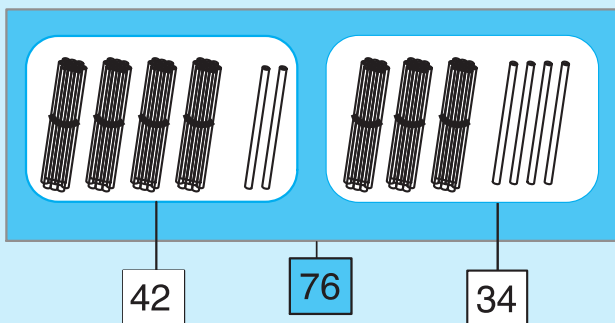

<input type="text"/>	+	<input type="text"/>	=	<input type="text"/>
<input type="text"/>	+	<input type="text"/>	=	<input type="text"/>
<input type="text"/>	-	<input type="text"/>	=	<input type="text"/>
<input type="text"/>	-	<input type="text"/>	=	<input type="text"/>

3



? $30 + 6 \dots 6 + 30$; $45 + 2 \dots 3 + 45$; $55 \dots 50 + 4$

4 Đúng ghi đ, sai ghi s (theo mẫu) :

$15 + 2$	$6 + 12$	$31 + 10$	$21 + 22$
<input type="text"/>	<input type="text"/>	<input type="text"/>	<input type="text"/>
<input type="text"/>	<input type="text"/>	<input type="text"/>	<input type="text"/>
<input type="text"/>	<input type="text"/>	<input type="text"/>	<input type="text"/>

ĐỒNG HỒ. THỜI GIAN

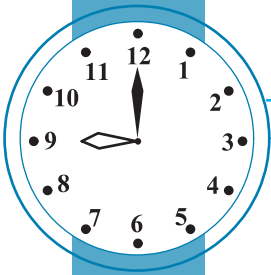

Đồng hồ chỉ 9 giờ

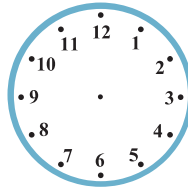

Mặt đồng hồ



Kim dài



Kim ngắn



5 giờ



6 giờ



7 giờ



Đồng hồ chỉ mấy giờ ?



.....

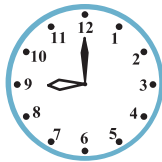

.....



.....

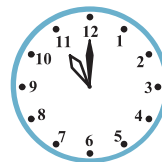

.....

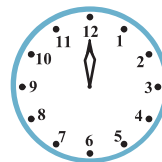

.....



.....



.....



.....

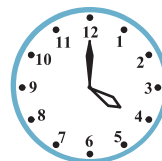

.....

THỰC HÀNH



1  **Viết (theo mẫu) :**



3 giờ



.....



.....

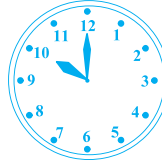

.....



.....

2  **Vẽ thêm kim ngắn để đồng hồ chỉ giờ đúng (theo mẫu) :**

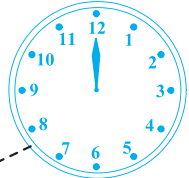
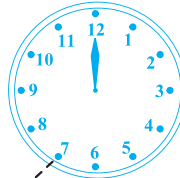
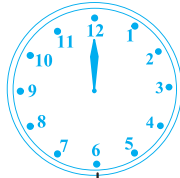
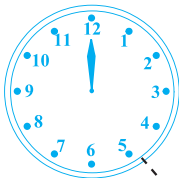

1 giờ	2 giờ	3 giờ	4 giờ	5 giờ
6 giờ	7 giờ	8 giờ	9 giờ	10 giờ

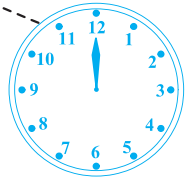
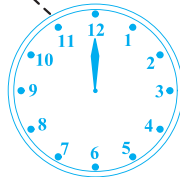
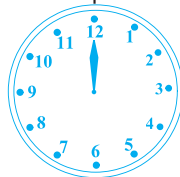
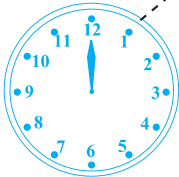
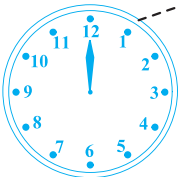

3  Nói tranh với đồng hồ thích hợp :

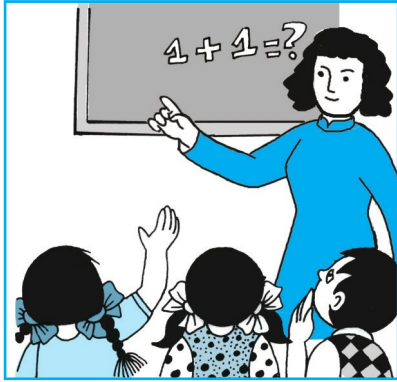

Buổi sáng : học ở trường

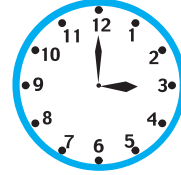
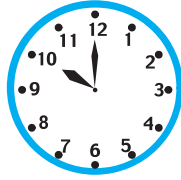

Buổi trưa : ăn cơm



Buổi chiều : học nhóm

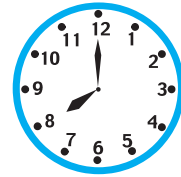

Buổi tối : nghỉ ở nhà

4  Bạn An đi từ thành phố về quê. Vẽ thêm kim ngắn thích hợp vào mỗi đồng hồ.

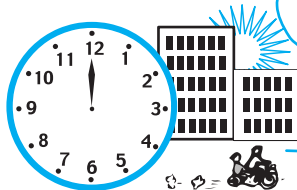
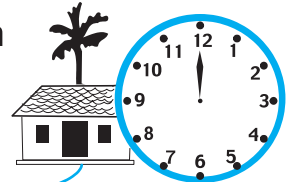

LUYỆN TẬP



1 Nối đồng hồ với số chỉ giờ đúng :

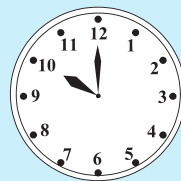
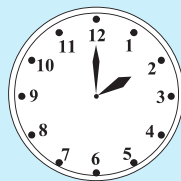
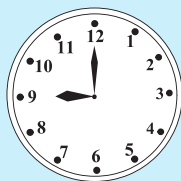
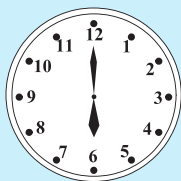
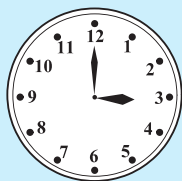

9 giờ

6 giờ

3 giờ

10 giờ

2 giờ

2 Quay các kim trên mặt đồng hồ để đồng hồ chỉ :

a) 11 giờ ;

b) 5 giờ ;

c) 3 giờ ;

d) 6 giờ

e) 7 giờ ;

g) 8 giờ ;

h) 10 giờ ;

i) 12 giờ.

3 Nối mỗi câu với đồng hồ thích hợp (theo mẫu) :

Em ngủ dậy lúc 6 giờ sáng

Em đi học lúc 7 giờ

Em học xong buổi sáng lúc 11 giờ

Em học buổi chiều lúc 2 giờ

Em tưới hoa buổi chiều lúc 5 giờ

Em đi ngủ lúc 9 giờ tối

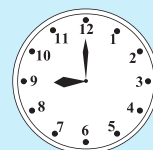
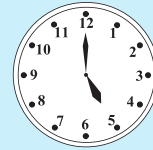
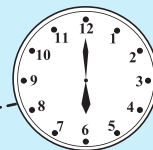



LUYỆN TẬP CHUNG

1  Đặt tính rồi tính :

$37 + 21$

$47 - 23$

$49 + 20$

$39 - 16$

$52 + 14$

$56 - 33$

$42 - 20$

$52 + 25$

2  Tính : $23 + 2 + 1 =$ $40 + 20 + 1 =$ $90 - 60 - 20 =$

3  Đo rồi viết số đo độ dài đoạn thẳng AB, đoạn thẳng BC. Tính độ dài đoạn thẳng AC.

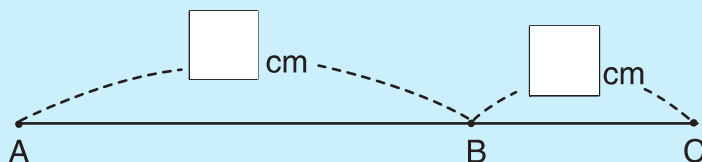

4  Nối đồng hồ với câu thích hợp :

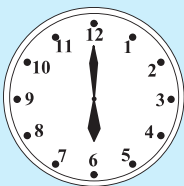

Bạn An ngủ dậy lúc 6 giờ sáng

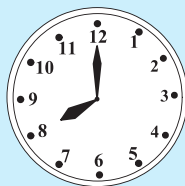

Bạn An tưới hoa lúc 5 giờ chiều

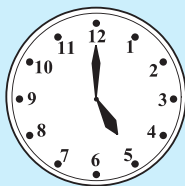

Bạn An ngồi học lúc 8 giờ sáng

LUYỆN TẬP CHUNG



1 



a) $32 + 7 \dots 40$

b) $32 + 14 \dots 14 + 32$

$45 + 4 \dots 54 + 5$

$69 - 9 \dots 96 - 6$

$55 - 5 \dots 40 + 5$

$57 - 1 \dots 57 + 1$

2 

Một thanh gỗ dài 97cm, bố em cưa bớt đi 2cm. Hỏi thanh gỗ còn lại dài bao nhiêu xăng-ti-mét ?

3 

Giải bài toán theo tóm tắt sau :

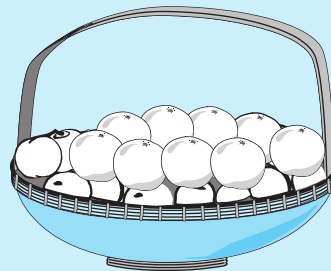
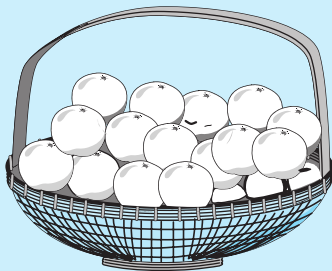

Giỏ 1 có : 48 quả cam

Giỏ 2 có : 31 quả cam

Tất cả có : ... quả cam ?

4 

Kẻ thêm một đoạn thẳng để có :

a) Một hình vuông và một hình tam giác

b) Hai hình tam giác

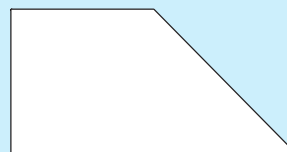
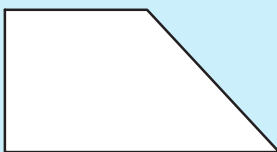



ÔN TẬP : CÁC SỐ ĐẾN 10

1  Viết số từ 0 đến 10 vào dưới mỗi vạch của tia số :

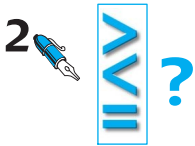

- | | | | |
|------------|----------|---------|----------|
| a) 9 ... 7 | 2 ... 5 | 0 ... 1 | 8 ... 6 |
| 7 ... 9 | 5 ... 2 | 1 ... 0 | 6 ... 6 |
| b) 6 ... 4 | 3 ... 8 | 5 ... 1 | 2 ... 6 |
| 4 ... 3 | 8 ... 10 | 1 ... 0 | 6 ... 10 |
| 6 ... 3 | 3 ... 10 | 5 ... 0 | 2 ... 2 |

3  a) Khoanh vào số lớn nhất :

6 , 3 , 4 , 9

b) Khoanh vào số bé nhất :

5 , 7 , 3 , 8 .

4  Viết các số 10, 7, 5, 9 theo thứ tự :

a) Từ bé đến lớn :

b) Từ lớn đến bé :

5  Đo độ dài của các đoạn thẳng :

A B

M N

P Q

ÔN TẬP : CÁC SỐ ĐẾN 10



1  Tính :

$2 + 1 =$	$3 + 1 =$	$4 + 1 =$	$5 + 1 =$	$6 + 1 =$	$7 + 1 =$
$2 + 2 =$	$3 + 2 =$	$4 + 2 =$	$5 + 2 =$	$6 + 2 =$	$7 + 2 =$
$2 + 3 =$	$3 + 3 =$	$4 + 3 =$	$5 + 3 =$	$6 + 3 =$	$7 + 3 =$
$2 + 4 =$	$3 + 4 =$	$4 + 4 =$	$5 + 4 =$	$6 + 4 =$	
$2 + 5 =$	$3 + 5 =$	$4 + 5 =$	$5 + 5 =$		$8 + 1 =$
$2 + 6 =$	$3 + 6 =$	$4 + 6 =$			$8 + 2 =$
$2 + 7 =$	$3 + 7 =$				
$2 + 8 =$					$9 + 1 =$

2  Tính :

a) $6 + 2 =$ $1 + 9 =$ $3 + 5 =$ $2 + 8 =$ $4 + 0 =$
 $2 + 6 =$ $9 + 1 =$ $5 + 3 =$ $8 + 2 =$ $0 + 4 =$

b) $7 + 2 + 1 =$ $8 + 1 + 1 =$ $9 + 1 + 0 =$
 $5 + 3 + 1 =$ $4 + 4 + 0 =$ $1 + 5 + 3 =$
 $3 + 2 + 2 =$ $6 + 1 + 3 =$ $4 + 0 + 5 =$

3 

Số ? $3 + \dots = 7$ $6 - \dots = 1$ $\dots + 8 = 8$
 $\dots + 5 = 10$ $9 - \dots = 3$ $9 - 7 = \dots$
 $8 + \dots = 9$ $5 + \dots = 9$ $5 - \dots = 5$

4  Nối các điểm để có :

a) Một hình vuông



b) Một hình vuông và hai hình tam giác





ÔN TẬP : CÁC SỐ ĐẾN 10

1 Số ?

$2 = 1 + \dots$

$8 = 7 + \dots$

$9 = 5 + \dots$

$3 = 2 + \dots$

$8 = \dots + 2$

$9 = \dots + 2$

$5 = 4 + \dots$

$8 = \dots + 4$

$10 = \dots + 4$

$7 = \dots + 2$

$6 = 4 + \dots$

$10 = 8 + \dots$

2 Viết số thích hợp vào ô trống :

$6 \xrightarrow{+3} \square$

$9 \xrightarrow{-5} \square$

$8 \xrightarrow{+2} \square$

$4 \xrightarrow{+2} \square \xrightarrow{+3} \square$

$9 \xrightarrow{-3} \square \xrightarrow{-1} \square$

3  Lan gấp được 10 cái thuyền, Lan cho em 4 cái thuyền. Hỏi Lan còn mấy cái thuyền ?

4  Vẽ đoạn thẳng MN có độ dài 10cm.

ÔN TẬP : CÁC SỐ ĐẾN 10



1  Tính :

$10 - 1 =$	$9 - 1 =$	$8 - 1 =$	$7 - 1 =$	$6 - 1 =$	$5 - 1 =$	$3 - 1 =$
$10 - 2 =$	$9 - 2 =$	$8 - 2 =$	$7 - 2 =$	$6 - 2 =$	$5 - 2 =$	$3 - 2 =$
$10 - 3 =$	$9 - 3 =$	$8 - 3 =$	$7 - 3 =$	$6 - 3 =$	$5 - 3 =$	$3 - 3 =$
$10 - 4 =$	$9 - 4 =$	$8 - 4 =$	$7 - 4 =$	$6 - 4 =$	$5 - 4 =$	
$10 - 5 =$	$9 - 5 =$	$8 - 5 =$	$7 - 5 =$	$6 - 5 =$	$5 - 5 =$	$2 - 1 =$
$10 - 6 =$	$9 - 6 =$	$8 - 6 =$	$7 - 6 =$	$6 - 6 =$		$2 - 2 =$
$10 - 7 =$	$9 - 7 =$	$8 - 7 =$	$7 - 7 =$		$4 - 1 =$	
$10 - 8 =$	$9 - 8 =$	$8 - 8 =$			$4 - 2 =$	$1 - 1 =$
$10 - 9 =$	$9 - 9 =$				$4 - 3 =$	
$10 - 10 =$					$4 - 4 =$	

2  Tính :

$5 + 4 =$	$1 + 6 =$	$4 + 2 =$	$9 + 1 =$	$2 + 7 =$
$9 - 5 =$	$7 - 1 =$	$6 - 4 =$	$10 - 9 =$	$9 - 2 =$
$9 - 4 =$	$7 - 6 =$	$6 - 2 =$	$10 - 1 =$	$9 - 7 =$

3  Tính :

$9 - 3 - 2 =$	$7 - 3 - 2 =$	$10 - 5 - 4 =$
$10 - 4 - 4 =$	$5 - 1 - 1 =$	$4 + 2 - 2 =$

4  Vừa gà vừa vịt có tất cả 10 con, trong đó có 3 con gà. Hỏi có mấy con vịt ?





ÔN TẬP : CÁC SỐ ĐẾN 100

1 Viết các số :

- a) Từ 11 đến 20 :
- b) Từ 21 đến 30 :
- c) Từ 48 đến 54 :
- d) Từ 69 đến 78 :
- đ) Từ 89 đến 96 :
- e) Từ 91 đến 100 :

2 Viết số vào dưới mỗi vạch của tia số :

- a) 
0
- b) 
90

3 Viết (theo mẫu) :

$$35 = 30 + 5 ; \quad 27 = \dots + \dots ; \quad 19 = \dots + \dots ; \quad 88 = \dots + \dots$$

$$45 = \dots + \dots ; \quad 47 = \dots + \dots ; \quad 79 = \dots + \dots ; \quad 98 = \dots + \dots$$

$$95 = \dots + \dots ; \quad 87 = \dots + \dots ; \quad 99 = \dots + \dots ; \quad 28 = \dots + \dots$$

4 Tính :

a)

$\begin{array}{r} 24 \\ + 31 \\ \hline \end{array}$	$\begin{array}{r} 53 \\ + 40 \\ \hline \end{array}$	$\begin{array}{r} 45 \\ + 33 \\ \hline \end{array}$	$\begin{array}{r} 36 \\ + 52 \\ \hline \end{array}$	$\begin{array}{r} 70 \\ + 20 \\ \hline \end{array}$	$\begin{array}{r} 91 \\ + 4 \\ \hline \end{array}$
---	---	---	---	---	--

b)

$\begin{array}{r} 68 \\ - 32 \\ \hline \end{array}$	$\begin{array}{r} 74 \\ - 11 \\ \hline \end{array}$	$\begin{array}{r} 96 \\ - 35 \\ \hline \end{array}$	$\begin{array}{r} 87 \\ - 50 \\ \hline \end{array}$	$\begin{array}{r} 60 \\ - 10 \\ \hline \end{array}$	$\begin{array}{r} 59 \\ - 3 \\ \hline \end{array}$
---	---	---	---	---	--

ÔN TẬP : CÁC SỐ ĐẾN 100



1 Viết các số :

Ba mươi tám, hai mươi tám, năm mươi tu, sáu mươi mốt, ba mươi, mười chín, bảy mươi chín, tám mươi ba, bảy mươi bảy.

2 Viết số thích hợp vào ô trống :

Số liền trước	Số đã biết	Số liền sau
	19	
	55	
	30	
	78	
	44	
	99	

3 a) Khoanh vào số bé nhất :

59 , 34 , 76 , 28

b) Khoanh vào số lớn nhất :

66 , 39 , 54 , 58.

4 Đặt tính rồi tính :

$$68 - 31$$

$$52 + 37$$

$$35 + 42$$

$$98 - 51$$

$$26 + 63$$

$$75 - 45$$

5 Thành gấp được 12 máy bay, Tâm gấp được 14 máy bay. Hỏi cả hai bạn gấp được bao nhiêu máy bay ?



ÔN TẬP : CÁC SỐ ĐẾN 100

1 Tính nhẩm :

a)	$60 + 20 =$	$80 - 20 =$	$40 + 50 =$
	$70 + 10 =$	$90 - 10 =$	$90 - 40 =$
	$50 + 30 =$	$70 - 50 =$	$90 - 50 =$

b)	$62 + 3 =$	$85 - 1 =$	$84 + 1 =$
	$41 + 1 =$	$68 - 2 =$	$85 - 1 =$
	$28 + 0 =$	$29 - 3 =$	$85 - 84 =$

2 Tính :

$15 + 2 + 1 =$	$68 - 1 - 1 =$	$77 - 7 - 0 =$
$34 + 1 + 1 =$	$84 - 2 - 2 =$	$99 - 1 - 1 =$

3 Đặt tính rồi tính :

$63 + 25$	$87 - 14$	$31 + 56$
$94 - 34$	$62 - 62$	$55 - 33$

4  Lan có sợi dây dài 72cm, Lan cắt đi 30cm. Hỏi sợi dây còn lại dài bao nhiêu xăng-ti-mét ?

5 Đồng hồ chỉ mấy giờ ?

a)

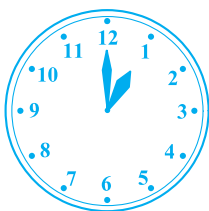

.....

b)

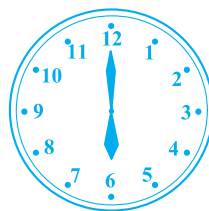

.....

c)

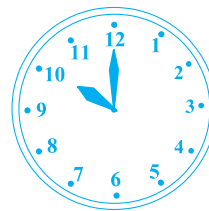

.....

ÔN TẬP : CÁC SỐ ĐẾN 100



1  **Viết số thích hợp vào ô trống :**



1	2	3	4	5	6	7	8	9	10
11	12	13		15	16	17	18		20
	22	23	24		26	27	28	29	30
31	32		34	35	36		38	39	40
41	42	43		45		47	48	49	
51	52	53	54	55	56	57		59	60
61		63	64		66	67	68		70
71	72		74	75	76		78	79	
	82	83		85		87	88	89	90
91		93	94	95	96	97	98		100

2  **Viết số thích hợp vào ô trống :**

- a)

82	83			86				
----	----	--	--	----	--	--	--	--
- b)

45	44		42	41				
----	----	--	----	----	--	--	--	--
- c)

	30	40	50		70	80		
--	----	----	----	--	----	----	--	--

3 

- Tính :
- a) $22 + 36 =$ $96 - 32 =$ $62 - 30 =$
 $89 - 47 =$ $44 + 44 =$ $45 - 5 =$
 b) $32 + 3 - 2 =$ $56 - 20 - 4 =$ $23 + 14 - 15 =$

4  Mẹ nuôi gà và thỏ, tất cả có 36 con, trong đó có 12 con thỏ. Hỏi mẹ nuôi bao nhiêu con gà ?

5  **Đo độ dài đoạn thẳng AB :**





LUYỆN TẬP CHUNG

1 Viết số :



Năm, mười chín, bảy mươi tư, chín, ba mươi tám, sáu mươi chín, không, bốn mươi mốt, năm mươi lăm.

2  Tính :

a) $4 + 2 =$	$10 - 6 =$	$3 + 4 =$	$14 + 4 =$
$8 - 5 =$	$19 + 0 =$	$2 + 8 =$	$18 - 5 =$
$3 + 6 =$	$17 - 6 =$	$10 - 7 =$	$12 + 7 =$

b)

$\begin{array}{r} 51 \\ + 38 \\ \hline \end{array}$	$\begin{array}{r} 62 \\ - 12 \\ \hline \end{array}$	$\begin{array}{r} 47 \\ + 30 \\ \hline \end{array}$	$\begin{array}{r} 96 \\ - 24 \\ \hline \end{array}$	$\begin{array}{r} 34 \\ + 34 \\ \hline \end{array}$	$\begin{array}{r} 79 \\ - 27 \\ \hline \end{array}$
---	---	---	---	---	---

3   

35 ... 42	90 ... 100	38 ... 30 + 8
87 ... 85	69 ... 60	46 ... 40 + 5
63 ... 36	50 ... 50	94 ... 90 + 5

4  Một băng giấy dài 75cm, em cắt bỏ đi 25cm. Hỏi băng giấy còn lại dài bao nhiêu xăng-ti-mét ?

5 Đo rồi ghi số đo độ dài từng đoạn thẳng :



.....



.....

LUYỆN TẬP CHUNG



1 Số ?

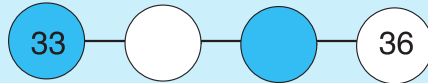

2 Đặt tính rồi tính :

$$36 + 12$$

$$84 + 11$$

$$46 + 23$$

$$97 - 45$$

$$63 - 33$$

$$65 - 65$$

3 Viết các số 28, 76, 54, 74 theo thứ tự :

a) Từ lớn đến bé :

b) Từ bé đến lớn :

4  Nhà em có 34 con gà, đã bán đi 12 con gà. Hỏi nhà em còn lại bao nhiêu con gà ?

5  Số ? a) $25 + \square = 25$

b) $25 - \square = 25$



LUYỆN TẬP CHUNG

1  a) Viết số liền trước của mỗi số sau :

35 ; 42 ; 70 ; 100 ; 1.

.....
.....
.....

b) Viết số liền sau của mỗi số sau :

9 ; 37 ; 62 ; 99 ; 11.

.....
.....
.....

2  Tính nhẩm :

$14 + 4 =$	$29 - 5 =$	$5 + 5 =$	$10 - 2 =$
$18 + 1 =$	$26 - 2 =$	$38 - 2 =$	$42 + 0 =$
$17 + 2 =$	$10 - 5 =$	$34 - 4 =$	$49 - 8 =$

3  Đặt tính rồi tính :

$43 + 23$	$60 + 38$	$41 + 7$
$87 - 55$	$72 - 50$	$56 - 5$

4  Hà có 24 viên bi đỏ và 20 viên bi xanh. Hỏi Hà có tất cả bao nhiêu viên bi ?

5  Vẽ đoạn thẳng dài 9cm.

LUYỆN TẬP CHUNG



1  Viết số dưới mỗi vạch của tia số rồi đọc các số đó :

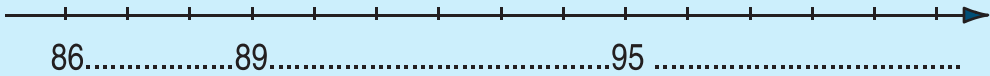

2  a) Khoanh vào số lớn nhất :

72 , 69 , 85 , 47

b) Khoanh vào số bé nhất :

50 , 48 , 61 , 58.

3  Đặt tính rồi tính :

$$35 + 40$$

$$73 - 53$$

$$88 - 6$$

$$86 - 52$$

$$5 + 62$$

$$33 + 55$$

4  Quyển vở của Lan có 48 trang, Lan đã viết hết 22 trang. Hỏi quyển vở còn bao nhiêu trang chưa viết ?

5  Nối đồng hồ với câu thích hợp :

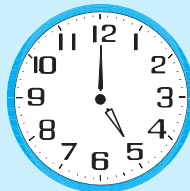

Em đi học
lúc 7 giờ sáng



Em tập múa
lúc 2 giờ chiều



Em trở về nhà
lúc 5 giờ chiều

1. CÁC SỐ ĐẾN 10. HÌNH VUÔNG, HÌNH TRÒN, HÌNH TAM GIÁC

• Tiết học đầu tiên	.4	• Luyện tập	.50
• Nhiều hơn, ít hơn	.6	• Số 0 trong phép cộng	.51
• Hình vuông, hình tròn	.7	• Luyện tập	.52
• Hình tam giác	.9	• Luyện tập chung	.53
• Luyện tập	.10	• Phép trừ trong phạm vi 3	.54
• Các số 1, 2, 3	.11	• Luyện tập	.55
• Luyện tập	.13	• Phép trừ trong phạm vi 4	.56
• Các số 1, 2, 3, 4, 5	.14	• Luyện tập	.57
• Luyện tập	.16	• Phép trừ trong phạm vi 5	.58
• Bé hơn. Dấu <	.17	• Luyện tập	.60
• Lớn hơn. Dấu >	.19	• Số 0 trong phép trừ	.61
• Luyện tập	.21	• Luyện tập	.62
• Bằng nhau. Dấu =	.22	• Luyện tập chung	.63
• Luyện tập	.24	• Luyện tập chung	.64
• Luyện tập chung	.25	• Phép cộng trong phạm vi 6	.65
• Số 6	.26	• Phép trừ trong phạm vi 6	.66
• Số 7	.28	• Luyện tập	.67
• Số 8	.30	• Phép cộng trong phạm vi 7	.68
• Số 9	.32	• Phép trừ trong phạm vi 7	.69
• Số 0	.34	• Luyện tập	.70
• Số 10	.36	• Phép cộng trong phạm vi 8	.71
• Luyện tập	.38	• Phép trừ trong phạm vi 8	.73
• Luyện tập chung	.40	• Luyện tập	.75
• Luyện tập chung	.42	• Phép cộng trong phạm vi 9	.76

2. PHÉP CỘNG, PHÉP TRỪ TRONG PHẠM VI 10

• Phép cộng trong phạm vi 3	.44	• Luyện tập	.82
• Luyện tập	.45	• Phép trừ trong phạm vi 10	.83
• Phép cộng trong phạm vi 4	.47	• Luyện tập	.85
• Luyện tập	.48	• Bảng cộng và bảng trừ trong phạm vi 10	.86
• Phép cộng trong phạm vi 5	.49	• Luyện tập	.88
		• Luyện tập chung	.89
		• Luyện tập chung	.90
		• Luyện tập chung	.91
		• Luyện tập chung	.92

3. CÁC SỐ TRONG PHẠM VI 100. ĐỘ DÀI. GIẢI BÀI TOÁN

● Điểm. Đoạn thẳng	94
● Độ dài đoạn thẳng	96
● Thực hành đo độ dài	98
● Một chục. Tia số	99
● Mười một, mười hai	101
● Mười ba, mười bốn, mười lăm	103
● Mười sáu, mười bảy, mười tám, mười chín	105
● Hai mươi. Hai chục	107
● Phép cộng dạng $14 + 3$	108
● Luyện tập	109
● Phép trừ dạng $17 - 3$	110
● Luyện tập	111
● Phép trừ dạng $17 - 7$	112
● Luyện tập	113
● Luyện tập chung	114
● Bài toán có lời văn	115
● Giải toán có lời văn	117
● Xăng-ti-mét. Đo độ dài	119
● Luyện tập	121
● Luyện tập	122
● Vẽ đoạn thẳng có độ dài cho trước	123
● Luyện tập chung	124
● Luyện tập chung	125
● Các số tròn chục	126
● Luyện tập	128
● Cộng các số tròn chục	129
● Luyện tập	130
● Trừ các số tròn chục	131
● Luyện tập	132
● Điểm ở trong, điểm ở ngoài một hình	133
● Luyện tập chung	135
● Các số có hai chữ số	136
● Các số có hai chữ số (tiếp theo)	138
● Các số có hai chữ số (tiếp theo)	140
● So sánh các số có hai chữ số	142
● Luyện tập	144
● Bảng các số từ 1 đến 100	145

● Luyện tập	146
● Luyện tập chung	147
● Giải toán có lời văn (tiếp theo)	148
● Luyện tập	150
● Luyện tập	151
● Luyện tập chung	152

4. PHÉP CỘNG, PHÉP TRỪ TRONG PHẠM VI 100. ĐO THỜI GIAN

● Phép cộng trong phạm vi 100 (cộng không nhớ)	154
● Luyện tập	156
● Luyện tập	157
● Phép trừ trong phạm vi 100 (trừ không nhớ)	158
● Phép trừ trong phạm vi 100 (trừ không nhớ)	159
● Luyện tập	160
● Các ngày trong tuần lễ	161
● Cộng, trừ (không nhớ) trong phạm vi 100	162
● Luyện tập	163
● Đồng hồ. Thời gian	164
● Thực hành	165
● Luyện tập	167
● Luyện tập chung	168
● Luyện tập chung	169
● Ôn tập: Các số đến 10	170
● Ôn tập: Các số đến 10	171
● Ôn tập: Các số đến 10	172
● Ôn tập: Các số đến 10	173
● Ôn tập: Các số đến 100	174
● Ôn tập: Các số đến 100	175
● Ôn tập: Các số đến 100	176
● Ôn tập: Các số đến 100	177
● Luyện tập chung	178
● Luyện tập chung	179
● Luyện tập chung	180
● Luyện tập chung	181

Chịu trách nhiệm xuất bản :
Chủ tịch Hội đồng Thành viên kiêm Tổng Giám đốc **NGUYỄN NGÔ TRẦN ÁI**
Phó Tổng Giám đốc kiêm Tổng biên tập **GS.TS VŨ VĂN HÙNG**

Biên tập lần đầu :

VŨ MAI HƯƠNG

VŨ VĂN DƯƠNG

Biên tập tái bản :

VŨ THỊ ÁI NHU

Biên tập mỹ thuật :

TÀO THANH HUYỀN

Thiết kế sách :

NGUYỄN THANH LONG

Minh họa và trình bày bìa :

NGUYỄN QUANG VINH

TÀO THANH HUYỀN

Sửa bản in :

VŨ THỊ ÁI NHU

Chế bản :

CÔNG TY CỔ PHẦN MỸ THUẬT VÀ TRUYỀN THÔNG

Bản quyền thuộc Nhà xuất bản Giáo dục Việt Nam - Bộ Giáo dục và Đào tạo.

TOÁN 1

Mã số : 1H103T4

Số đăng kí KHXB : 01-2014/CXB/67-1062/GD

In cuốn (QĐ in số, khổ 17x24(cm), In tại

In xong và nộp lưu chiểu tháng năm 2014.



HUÂN CHƯƠNG HỒ CHÍ MINH



SÁCH GIÁO KHOA LỚP 1

1. TIẾNG VIỆT 1 (tập một, tập hai)
2. TOÁN 1
3. TỰ NHIÊN VÀ XÃ HỘI 1
4. TẬP VIẾT 1 (tập một, tập hai)

mã vạch



Tem chống giả

Giá: